

City of Guyton, Georgia  
CITY COUNCIL MEETING  
August 8, 2023 at 7:00 P.M.



**C.D. Dean, Jr. Public Safety Complex  
GUYTON GYMNASIUM  
505 Magnolia Street  
Guyton, GA 31312**

---

## **AGENDA**

- 1. Call to Order**
  - 2. Invocation and Pledge of Allegiance**
  - 3. Consideration to Approve the Agenda**
  - 4. Reports from Staff or Committees**

Police Department	James Breletic
Fire Department	Clint Hodges
Public Works/Water/Sewer	EOM
Planning and Zoning	Lon Harden
Industrial Development	Lon Harden
Historical Commission	Lucy Powell
Leisure Services	Lula Seabrooks
Hospital Authority	Tamela Mydell
Library Board	Jim Odum
Chamber of Commerce	Hursula Pelote
  - 5. Public Comments (will be limited to Agenda Items only)**
  - 6. Old Business**
    - a. Second reading and consideration of Ordinance 2023-07 authorizing the Board of Elections and Registration of Effingham County to conduct the City of Guyton's Municipal Elections to occur during the 2023 elections cycle
    - b. Consideration to approve agreement with Judicial Alternatives of Georgia for Probation Services
  - 7. New Business**
    - a. Consideration of Resolution 2023-09 to approve an Intergovernmental Agreement authorizing the Board of Elections and Registration of Effingham County to conduct the City of Guyton's Municipal Elections to occur during the 2023 elections cycle
    - b. First reading of Ordinance 2023-08 levying a Net Tax to meet the ordinary current and extraordinary expenses of the City of Guyton, Georgia for the Tax Year 2023
    - c. First reading of Ordinance 2023-09 creating the positions of Finance Clerk, Code Enforcement Officer, and Receptionist
-

- d. Consideration to approve Intergovernmental Agreement for use and distribution of proceeds generated by the 2023 TSPLOST Referendum and the City of Guyton TSPLOST Project List
- e. Consideration to run an ad in the 2023-2024 Effingham Chamber of Commerce Community Guide and Business Directory
- f. Consideration to approve 2024 EGG Earth Day Festival and Spring Sale Along the Trail to be held on April 20, 2024
- g. Consideration to approve Effingham Health Systems Foundation Breast Cancer Awareness 5k in Guyton on October 14, 2023
- h. Consideration to approve funds for the Recodification of Guyton's Code of Ordinances with CivicPlus
- i. Consideration to approve \$3805 for HVAC repairs at the C.D. Dean, Jr. Public Safety Complex

**8. General Government**

- a. Sale Along the Trail

**9. Dates to Remember**

- a. Wednesday, August 9, 2023 from 5:00pm to 7:00pm – Guyton Historical Summer Social, Guyton Walking Trail, 310 Central Boulevard, Guyton GA 31312
- b. August 10, August 24, September 7, September 21 11:00am to 12:00pm Bingo – Leisure Services Room, 505 Magnolia Street, Guyton, GA 31312
- c. Tuesday, August 15, 2023 at 7:00pm – Guyton City Council Special Called Meeting, Guyton Gymnasium, 505 Magnolia Street, Guyton, GA 31312
- d. Tuesday, August 22, 2023 at 7:00pm – Planning and Zoning Public Hearing and Meeting, Guyton Gymnasium, 505 Magnolia Street, Guyton, GA 31312
- e. August 22, 23, and 24 from 8:30am to 4:30pm – Qualifying for the 2023 City Election, Guyton City Hall, 310 Central Boulevard, Guyton GA 31312
- f. City Hall will be closed September 4, 2023 for Labor Day
- g. Tuesday, September 12, 2023 at 7:00pm – Guyton City Council Meeting, Guyton Gymnasium, 505 Magnolia Street, Guyton, GA 31312

**10. Consideration to move from the Regular Meeting into an Executive Session referencing Property**

**11. Consideration to take any action needed arising from Executive Session**

**12. Public Comments (will be limited to Agenda Items only)**

**13. Consideration to adjourn this meeting**

## Rules of Decorum for All Meetings

The purpose of the Rules of Decorum is to foster an atmosphere of civil and courteous discourse, even and especially when discussing contentious topics, at all meetings held by the City of Guyton.

### (a) General rules applicable to all (Mayor and Council, Staff, Members of the Public)

1. Each speaker will direct his or her comments to the Mayor and or presiding officer and not to any other individual present.
2. Each speaker will refrain from personal attacks, foul or abusive language, and will maintain a civil and courteous manner and tone.
3. Each speaker will speak only about agenda items. Members of the public will be limited to 3:00 minutes speaking time.
4. Members of the audience will respect the rights of others and will not create noise or other disturbances that will disrupt or disturb persons who are addressing the Mayor and Council or Committee or Board or Commission, or members of those bodies who are speaking, or otherwise impede the orderly conduct of the meeting.

### (b) Additional Rules for Members of Mayor and Council, Committees, Boards or Commissions

1. Members of Mayor and Council, Committees, Boards or Commissions will conduct themselves in a professional and respectful manner at all meetings.
2. Members of Mayor and Council, Committees, Boards or Commissions will not speak until recognized by the Mayor or presiding officer.
3. Remarks by members of Mayor and Council, Committees, Boards or Commissions will be directed to the Mayor or presiding officer and not to individuals, other Council, Committee, Board or Commission members, staff or Members of the public in attendance. Questions for staff or individuals or other Council, Committee, Board or Commission members will be directed to the Mayor or presiding officer, who will then direct the appropriate person to answer.
4. Members of Mayor and Council, Committees, Boards or Commissions are always free to criticize or question policies, positions, data or information presented. However, members of Mayor and Council, Committees, Boards or Commissions will not attack or impugn the person presenting.

### (c) Enforcement

The Mayor or presiding officer has the authority to enforce each of the Rules of Decorum regarding members of the public. If any Rule is violated, the Mayor or presiding officer will give the speaker a warning, citing the Rule being violated, and telling the speaker that a second violation will result in a forfeiture of the right to speak further. The Mayor or presiding officer also may have the offending speaker removed from the meeting if the misconduct persists. The Mayor or presiding officer shall not have any power under this provision regarding a Council, Committee, Board or Commission member.

**CITY OF GUYTON  
STATE OF GEORGIA**

**ORDINANCE NUMBER 2023-07**

**AN ORDINANCE OF THE CITY OF GUYTON AUTHORIZING THE BOARD OF ELECTIONS AND REGISTRATION OF EFFINGHAM COUNTY TO CONDUCT THE CITY OF GUYTON’S MUNICIPAL ELECTIONS TO OCCUR DURING THE 2023 ELECTIONS CYCLE; TO PROVIDE AN EFFECTIVE DATE; TO REPEAL ALL ORDINANCES AND RESOLUTIONS AND PARTS THEREOF IN CONFLICT HEREWITH; AND FOR OTHER PURPOSES.**

**WHEREAS**, the duly elected governing authority of the City of Guyton, Georgia is authorized by O.C.G.A. §36-35-3 to adopt ordinances and resolutions relating to its property, affairs, and local government; and

**WHEREAS**, Section 5.15 of the Charter of the City of Guyton provides that except otherwise provided by the Charter, the City Council shall, by ordinance, prescribe such rules and regulations as it deems appropriate to fulfill any options under Chapter 2 of Title 21 of the O.C.G.A., the “Georgia Election Code”; and

**NOW, THEREFORE, IT IS HEREBY ORDAINED BY THE GOVERNING AUTHORITY OF THE CITY OF GUYTON, GEORGIA IN A REGULAR MEETING ASSEMBLED AND PURSUANT TO LAWFUL AUTHORITY THEREOF, AS FOLLOWS:**

**Section 1. Authorization of Effingham County Board of Elections and Registration to Conduct 2023 Municipal Elections.** The City Council of the City of Guyton hereby authorizes the Effingham County Board of Elections and Registration to conduct the City of Guyton’s municipal elections to occur in 2023, as well as any run-off elections occurring in 2023 to determine the victor of a race originally on the November 2023 ballot, pursuant to the Intergovernmental Agreement attached hereto as Exhibit A.

**Section 3. Severability.** If any section, clause, sentence or phrase of this ordinance is held to be invalid or unconstitutional by any court of competent jurisdiction, then said holding shall in no way affect the validity of the remaining portions of this ordinance.

**Section 4. Repealer.** All ordinances and resolutions and parts thereof in conflict with this ordinance are hereby repealed.

**Section 5. Effective Date.** This ordinance shall become effective immediately upon its adoption, so long the City of Guyton and Effingham County have, at the time this ordinance is adopted, executed the Intergovernmental Agreement attached hereto as Exhibit A. If the City of Guyton

and Effingham County have not executed that Agreement, this Ordinance shall become effective upon its execution.

SO ORDAINED, this \_\_\_\_ day of \_\_\_\_\_, 2023.

**CITY OF GUYTON**

---

Russ Deen, Mayor

Attest:

---

Meketa H. Brown, City Manager



# JUDICIAL ALTERNATIVES OF GEORGIA

## Probation Services Agreement

This Probation Services Agreement (this "Agreement") is made by and between **Judicial Alternatives of Georgia, Inc.**, a corporation, organized under the laws of the State of Georgia, with its principal place of business at 901 Bellevue Ave, Dublin Georgia (hereinafter called "Contractor"), **the City of Guyton, Georgia**, and the **Guyton Municipal Court**, 130 South Laurel Street, Guyton, Georgia (hereinafter called "Court"). This Agreement is governed by Article 6 of Chapter 8 of Title 42 of the Official Code of Georgia, Annotated. The parties enter into the Agreement under the specific authority of 42-8-101.

NOW, THEREFORE, in consideration of the mutual covenants herein contained, the parties agree as follows:

### SCOPE OF SERVICES AND RESPONSIBILITIES OF CONTRACTOR

In consideration of the obligations of the Court or governing authority of the City of Guyton, Contractor shall provide the following services.

#### A. Responsibilities of Probation Services Contractor

1.) Compliance with Statutes and Rules. Contractor shall comply with Article 6 of Title 42 Chapter 8 of the Official Code of Georgia and all standards, rules and regulations promulgated by the Department of Community Supervision.

2.) Records and Confidentiality. Contractor shall create and maintain individual files for each offender receiving services from Contractor in accordance with this Agreement. Contractor shall maintain the confidentiality of all files, records and papers relative to supervision of probationers under this Agreement. These records, files and papers shall be available only to the judge and authorized employees of the Court handling the case, the Department of Audits and Accounts,

the Department of Community Supervision and upon transfer of probation supervision to the State, to the Georgia Department of Corrections.

3.) Financial Records. Contractor shall maintain financial records according to generally accepted accounting practices.

4.) Employee Qualifications and Training. Contractor shall employ competent and able personnel to provide the services to be rendered hereunder and to appropriately administer the assigned caseload.

(a) Any person employed as JAG probation officer shall be at least 21 years of age at the time of appointment to the position of private probation officer and shall have completed a standard two-year college course or have four years of law enforcement experience; provided, however, that any person employed as a private probation officer as of July 1, 1996, and who had at least six months of experience as a private probation officer or any person employed as a probation officer by a county, municipality, or consolidated government as of March 1, 2006, shall be exempt from such college requirements.

b) Every JAG probation officer shall be required to obtain 40 hours of initial orientation training as set forth below provided that the 40 hour initial orientation shall not be required of any person who has successfully completed and who provides documentation of satisfactorily completing a basic course of training for supervision of probationers or parolees certified by the Peace Officer Standards and Training Council. Initial training of new probation officers shall be completed within the first 6 months of employment. JAG Probation Officers will complete a 5-hour block of instruction covering a General Probation Overview and consisting of: The History of Probation, Ethics and Professionalism, Probation Officer Liabilities and Responsibilities, Constitutional Law, and Probation Law; a 20-hour block of instruction covering Probationer Management and consisting of: Confidentiality, Intake, Preparation and Maintenance of Files, Case Documentation, Interviewing and Communication Skills, Available Sentencing Options, Financial Collections, Community Service, Alcohol and Substance Abuse, and Personal Welfare and Safety; and a 15-hour block of instruction covering Legal Procedures and Reports and consisting of: General Report Writing Techniques, Violations, Delinquency Reports and Warrants, Courtroom Protocol, Testimony and Revocation Proceedings, First Offender Act, Case Termination Reports, Domestic Violence, and Statutory Changes and Updates.

(c) All JAG probation officers are required to obtain 20 hours of annual in-service training. In-service training shall be completed on a calendar year basis. The initial orientation training hours completed during the first calendar year of employment shall also count towards satisfying the annual in-service training requirements for that same period. Annual In-Service Training shall be on topics that relate to the criminal justice system and/or the operation of the probation entity as approved by DCS Misdemeanor Probation Oversight Unit (MPOU).

(d) All JAG Administrative Employees, Agents, Interns, or Volunteers shall be required in accordance with DCS Board Rule 105-2-.09 to be at least 18 years of age; sign a statement co-signed by the probation entity director or his/her designee that the administrative employee, agent, intern, or volunteer has received an orientation on these rules as well as operations guidelines relevant to the administrative employee, agent, intern, or volunteer's job duties which shall be maintained in administrative employees, agents, interns, or volunteer's personnel files; have obtained a high school diploma or equivalent and; complete a 16 hour initial orientation program within 6 months of appointment and 8 hour annual in-service continuing education training program, consisting of a curriculum approved by MPOU. Additionally, such person shall maintain a clear criminal record; complete continuing education and; adhere to all other requirements established in these rules.

(e) All Administrative Employee, Agent, Intern, or Volunteer will obtain 16 hours of initial orientation training consisting of a 4-hour block of instruction covering: The History of Probation, Ethics and Professionalism, Probation Officer Liabilities and Responsibilities, Constitutional Law, and Probation Law; an 8-hour block of instruction covering Probationer Management and consisting of: Confidentiality, Intake, Preparation and Maintenance of Files, Case Documentation, Interviewing and Communication Skills, Available Sentencing Options, Financial Collections, Community Service, Alcohol and Substance Abuse, and Personal Welfare and Safety; and a 4-hour block of instruction covering Legal Procedures and Reports and consisting of: General Report Writing Techniques, Violations, Delinquency Reports and Warrants, Courtroom Protocol, Testimony and Revocation Proceedings, First Offender Act, Case Termination Reports, Domestic Violence, and Statutory Changes and Updates; obtain 8 hours of annual in-service training. In-service training shall be completed on a calendar year basis. The initial orientation training hours completed during the first calendar year of employment shall also count towards satisfying the annual in-service training requirements for that same period.

(f) Annual In-Service Training shall be on topics that relate to the criminal justice system and/or the operation of the probation entity as approved by MPOU. The progress and completion of initial orientation and in-service training is required to be documented and maintained in the individual's files utilizing the forms approved by MPOU. Probation entities and individuals providing probation services may obtain training resource information from MPOU, local law enforcement agencies, local colleges and schools, and national professional associations such as the American Probation and Parole Association, Georgia Professional Association of Community Supervision, American Correctional Association, and/or credible sources approved by MPOU. All training must be approved by MPOU.

(g) JAG trainers will have expertise in the area of training and will possess a college degree or POST certification. JAG shall maintain a description of the



course and the contact information of the trainer on file. Training provided by professional training services shall be accepted so long as a description of the course and the trainer's contact information is maintained on file and has been approved by MPOU.

(h) In no event shall any person convicted of a felony be employed as a private probation officer or administrative support staff.

5.) Criminal History Check. Contractor shall have a criminal history records check made of **all** employees and give written consent to the Department of Community Supervision or the City of Guyton to conduct periodic criminal history checks.

6.) Officer per Probationer Ratio and Standards of Supervision. Contractor shall manage caseload limits so as not to exceed **250** probationers per probation officer for basic supervision and **100** probationers per probation officer for intensive supervision. Probation Officers shall require a minimum of **1** office contact per **month** for each probationer supervised. The Probation Officer may at his or her discretion require the probationer to report on a weekly basis if the probationer is not in full compliance with his or her terms of conditions of supervision.

7.) The Contractor shall maintain an office within the county of **Effingham, Georgia** for meeting with and the provision of services to probationers.

## B. Reports

Contractor shall provide to the judge and governing authority with whom this Agreement was made a monthly report, on or before the 10<sup>th</sup> day of the following month, summarizing the number of offenders under supervision; the amount of fines, and restitution collected; the amount of fees collected and the nature of such fees, including probation supervision fees, rehabilitation programming fees, electronic monitoring fees, drug or alcohol detection device fees, substance abuse or mental health evaluation or treatment fees, and drug testing fees; the number of community service hours performed by probationers under supervision; a listing of any other service for which a probationer was required to pay to attend; the number of offenders for whom supervision or rehabilitation has been terminated and the reason for the termination; and the number of warrants issued during the month, in such detail as requested. Contractor shall provide personal history, employment data, and location information to the court or law enforcement as necessary in tracking probation violators.

## C. Tender of Collections

Contractor shall tender to the Clerk of the Court a report of collections and all fines, fees, and costs collected during the month from probationers by the 10<sup>th</sup> day of the following month. Restitution shall be paid to the victim by the 10<sup>th</sup> day of the month following collection unless the Court orders payment to the clerk of court, and then it shall be paid as such other collections are paid to the Clerk.

In the event Contractor cannot locate the victim, payment shall be made to the Clerk of Court. Contractor shall credit payments of funds to in the following order of priority: 1) restitution 2) probation fees to include GCVEF, 3) fines, 4) court costs and surcharges. Contractor shall not retain or profit from any fines, restitution, fees or cost collected from probationers except the probation fees authorized by this Agreement and listed in Exhibit "A".

#### D. Access to Contractor Records

1.) All records shall be open to inspection upon the request of the affected county, municipality, consolidated government, court, the Department of Audits and Accounts, an auditor appointed by the affected county, municipality, or consolidated government, Department of Corrections, Department of Community Supervision, or State Board of Pardons and Paroles.

2.) Fiscal Audit: Contractor shall employ an independent auditor to annually audit its records and books pertaining to the services rendered at the Court's request. Upon a written request by the court, a copy of this audit shall be provided to the Court and County Governing Authority within 2 months or sixty (60) days of the close of the year audited.

#### E. Conflict of Interest per O.C.G.A 42-8-109

1.) No private corporation, private enterprise, or private agency contracting to provide probation services under neither the provisions of this article nor any employees of such entities shall engage in any other employment, business, or activity which interferes or conflicts with the duties and responsibilities under contracts authorized in this article.

2.) No private corporation, private enterprise, or private agency contracting to provide probation services under the provisions of neither this article nor its employees shall have personal or business dealings, including the lending of money, with probationers under their supervision.

3.) No private corporation, private enterprise, or private agency contracting to provide probation services under the provisions of this article nor any employees of such entities, shall own, operate, have any financial interest in, be an instructor at, or be employed by any private entity which provides drug or alcohol education

services or offers a DUI Alcohol or Drug Use Risk Reduction Program certified by the Department of Driver Services.

4.) No private corporation, private enterprise, or private agency contracting to provide probation services under the provisions of this article nor any employees of such entities shall specify, directly or indirectly, a particular **DUI Alcohol or a Drug Use Risk Reduction Program** which a probationer may or shall attend. This paragraph shall not prohibit furnishing any probationer, upon request, with the names of certified DUI Alcohol or Drug Use Risk Reduction Programs. Any person violating this paragraph shall be guilty of a misdemeanor.

F. Scope of Services to Probationers by Contractor. Contractor shall provide the following services:

1.) Court Attendance and Probationer Case History. During all court sessions, Contractor shall have a probation officer attend and interview each offender to complete a case and personal history and to provide orientation and instruction regarding compliance with the Court's ordered conditions of probation. At orientation, the probation officer shall provide a list of all service fees to the probationer.

2.) Supervision. Contractor shall monitor and supervise probationers to ensure compliance with the Court's order of probation. Contractor shall make a supervision assessment of the offender and determine the probationer's reporting schedule.

3.) Restitution, Fine and Fee Collection. Contractor shall collect restitution, fines, court costs and fees, program fees, and probation fees as ordered by the Court. Contractor shall provide an itemized ledger prepared in accordance with accepted accounting practices for each month for each case under supervision.

(a) **Indigent Offenders**: Offenders determined by the court to be indigent in accordance with O. C. G.A 42-8-102 shall be supervised at no cost to the probationer or the Court or the City of Guyton.

(b) **Pay-Only Cases**: Pay-Only cases or the term 'pay-only probation' means a defendant has been placed under probation supervision **solely** because such defendant is unable to pay the court imposed fines and statutory surcharges when such defendant's sentence is imposed. Such term shall not include circumstances when restitution has been imposed or other probation services are deemed appropriate by the court. When pay-only probation is imposed, the probation supervision fees shall be capped so as not to exceed three months of ordinary probation supervision

regardless of the number of concurrent or consecutive cases; provided, however, that collection of any probation supervision fee shall terminate as soon as all court imposed fines and statutory surcharges are paid in full; and provided, further, that when all such fines and statutory surcharges are paid in full, the private probation officer, as the case may be, shall submit an order to the court terminating the sentence within 30 days of fulfillment of such conditions. If pay-only probation is subsequently converted to a sentence that requires community service, on petition by a probation officer or private probation officer and with the probationer having an opportunity for a hearing, the court may reinstate probation supervision fees as necessary to monitor the probationer's compliance with community service obligations.

(c) **Consecutive sentences**: When a defendant is serving consecutive misdemeanor sentences, whether as a result of one case from one jurisdiction or multiple cases from multiple jurisdictions, upon motion by the defendant, the court may discharge such defendant from further supervision or otherwise terminate probation when it is satisfied that its action would be in the best interest of justice and the welfare of society. Such motion shall not be ripe until 12 months after the sentence was entered and every four months thereafter. The defendant shall serve the applicable entity or governing authority that is providing his or her probation services with a copy of such motion. Additionally, when a defendant is serving consecutive misdemeanor sentences the probation officer shall review such case after 12 consecutive months of probation supervision wherein the defendant has paid in full all court imposed fines, statutory surcharges, and restitution and has otherwise completed all testing, evaluations, and rehabilitative treatment programs ordered by the court to determine if such officer recommends early termination of probation. Each such case shall be reviewed every four months thereafter for the same determination until the termination, expiration, or other disposition of the case. If such officer recommends early termination, he or she shall immediately submit an order to the court to effectuate such purpose.

4.) Community Service. The Contractor shall coordinate, monitor, and ensure compliance with community service by each probationer as ordered by the Court. The Court may convert fines, statutory surcharges, and probation supervision fees to community service on the same basis as it allows a defendant to pay a fine through community service as set forth in subsection (d) of Code Section 17-10-1. Contractor will maintain records of service participation.

5.) Employment Assistance. The Contractor shall prepare referrals and lend reasonable assistance to probationers either to the extent ordered by the Court or

to the extent available for probationers desiring employment assistance or counseling.

6.) Drug/Alcohol Screening. The Contractor shall coordinate with local authorities and facilities, evaluation and assessment of probationers for drug/alcohol rehabilitation, mental health or psychological counseling, or educational programs mandated by the Court and shall require probationer's compliance.

Contractor shall conduct drug and alcohol screens as determined necessary by the Court. The probationer shall be responsible for the costs of all drug or alcohol testing.

7.) Electronic Monitoring. Contractor when so ordered shall provide and operate a system of electronic home detention monitoring:

8.) Reports of Violations Probation and Revocation Procedures. The Contractor shall recommend revocation of probation whenever the probationer has failed to substantially comply with the terms and conditions of probation. The Court shall provide Contractor with direction of what constitutes a substantial failure to comply with probation terms and conditions. Contractor shall prepare probation violation warrants and orders for submission to the Court. Contractor shall have probation officers available to testify at probation revocation hearings, sentencing hearings and such other hearings as deemed reasonable and necessary by the Court. The Court shall provide Contractor direction as to what curative measures should be taken in the case of minor violations.

## **OBLIGATIONS OF THE COURT OR GOVERNING AUTHORITY**

In consideration for the services of Judicial Alternatives of Georgia, Inc the Court shall provide the following:

### **G. Payment for Contractors Services**

For regular probation supervision which includes a minimum of **one (1)** office contact per month and may require as many as **four (4)**, the probationer shall pay a fee of **\$45.00** per month. For intensive probation supervision which includes a minimum of **one (1)** office contact per week and **four (4)** office contacts each month, probationer shall pay a fee of **\$55.00** per month. Contractor shall collect such probation fee for each month a probationer is under probation supervision. A **one (1) month** supervision fee is defined as the date the probationer is placed on probation and runs through the monthly anniversary date each month. If a probationer is supervised past the monthly anniversary date, the probationer will be charged one (1) months supervision fee. During the

term of this Agreement and Contractor's satisfactory performance, the Court shall refer all offenders ordered to serve time on probation, to Contractor for purposes of probation supervision services.

#### H. Probation Fee

The Court shall make payment of the probation fee a term and condition of the order of probation for each probationer assigned for supervision to Contractor unless the Court determines the probationer to be indigent. The Court shall not be liable for payment of any supervision fee or any program fee of a probationer.

#### K. Notice of Court Sessions

The Court shall provide Contractor **two (2)** days advance notice of all court sessions that Contractor is required to attend. Notice for purposes of this provision may be given by mail, telephone and e-mail.

#### L. Court Facilities

The Court shall provide to Contractor an area, as available, for conduct of initial interviews and orientation with the probationer on the day of sentencing.

#### M. Period of Service

This agreement shall commence performance on **August 8, 2023** and shall continue until **September 1<sup>st</sup>, 2025**. Either party may terminate this Agreement upon Ninety (90) days written notice. The Court and/or Governing Authority of the City of Guyton may terminate this Agreement immediately for cause, including without limitation material breach of this Agreement, insolvency of Contractor, filing of a voluntary or involuntary case in bankruptcy. Within fifteen (15) working days of termination, the Contractor shall peacefully surrender to the Court all records and documents generated by Judicial Alternatives of Georgia, Inc, in connection with this Agreement and the services hereunder and any equipment or supplies assigned to Contractor by the Court. Contractor shall turn over to the Clerk of Court any moneys collected or received less supervision fees validly incurred and duly owing to Contractor through the termination date. Any fines, costs, fees or restitution received by Contractor from probationers of this Court after termination of this Agreement shall be forwarded to the Clerk of Court, other than fees earned by Contractor. The Court shall provide Contractor a receipt for all property surrendered under this provision.

### **INDEMNITY, INSURANCE, AND BONDING OBLIGATIONS OF CONTRACTOR**

#### N. Insurance and Bond

Contractor shall maintain comprehensive general liability insurance, including acts, errors or omissions and contractual liability insurance, in an amount not less than \$1,000,000. JAG shall furnish continuous proof of insurance coverage as required hereunder, as well as proof of maintaining employee bonds in an amount of \$100,000 per employee.

#### O. Indemnification

Neither the Court nor the City of Guyton Georgia shall be liable to Contractor nor to anyone who may claim a right resulting from any relationship with **Judicial Alternatives of Georgia, Inc**, for any acts of Contractor, its employees, agents or participants in the performance of services conducted on the property of or on behalf of the City of Guyton, Georgia or the Municipal Court of Guyton Georgia. Contractor shall indemnify and hold harmless the Court and the City of Guyton, Georgia from any claims, demands, actions, proceedings, expenses, damages, liabilities or losses (including but not limited to attorney's fees and court costs) and any causes of action arising from any acts or omissions arising out of or in connection with the services performed by **Judicial Alternatives of Georgia, Inc**, or its employees and agents under the terms of this Agreement.

### **REPRESENTATIONS AND WARRANTIES OF CONTRACTOR**

#### P. Deficiency in Service by Contractor

In the event that the Court and/or governing authority of the City of Guyton determines that there are deficiencies in the services provided by Contractor hereunder, the Court and/or Governing Authority may terminate this Agreement in accordance with Item M or notify the Contractor in writing as to the exact nature of such deficiency. Within **sixty (60) Days** of receipt of such notice, the Contractor shall cure or take reasonable steps to cure the deficiencies. In the event the Contractor fails to cure or take reasonable steps to cure the deficiencies to the Court and/or Governing Authority's satisfaction, then either may declare the Contractor in default and may terminate this Agreement.

#### Q. Time is of the Essence of this Agreement

#### R. Compliance with the Law

The Contractor shall comply with all federal, state and local laws statutes, regulations and ordinances arising out of or in connection with the performance of its services pursuant to this Agreement.

## S. Independent Contractor

Contractor is an independent contractor and is not an agent, joint venturer or other affiliate of the **City of Guyton** nor the **Municipal Court of Guyton Georgia** in any way. Contractor shall use its own employees and agents to perform its obligations under this Agreement. It is agreed that Contractor is solely responsible for payment of all federal, state, and local income taxes, self-employed Social Security taxes, and any other similar obligations arising from the performance of this Agreement or receipt of compensation therefore. The Contractor agrees to indemnify and hold harmless the **Municipal Court of Guyton, Georgia and the City of Guyton** from and against any and all federal, state, or local tax liabilities or penalties that may arise from the payments made to the Contractor pursuant to this Agreement. The Contractor acknowledges that neither it nor its employees are eligible for any benefits provided by the Court or City of Guyton to their respective employees.

## T. Entire Agreement

This Agreement, including all exhibits attached hereto and incorporated herein by reference, constitutes the entire agreement between the parties hereto and supersedes any and all agreements, whether written or oral, that may exist between the parties regarding the same. No representations, inducements, promises, or agreements between the parties not embodied herein shall be of any force and effect. No amendment or modification to this Agreement or any waiver of any provision hereto shall be effective unless in writing and signed by all parties to include the Court, governing authority of the City of Guyton, and Contractor.

## U. Binding Agreement

This Agreement shall not be binding upon any successor to the undersigned Chief Judge of the **Municipal Court of Guyton Georgia** unless ratified by their successor in office. If a successor attains the position of Chief Judge, and this Agreement is not ratified by such successor, then Contractor shall be permitted a reasonable time period, no less than ninety (90) days, in which to wind up its activities. The Court will be deemed not to have ratified this Agreement unless Court gives written notice of ratification within 30 days of taking the oath of office.

Contractor may not delegate, assign or subcontract any obligation of Contractor's performance under this Agreement and may not assign any right under this Agreement, in either case without Court's written approval. The Court's discretion in this regard shall be absolute.



Any notices made in accordance with this Agreement except as otherwise set out in Item K, shall be in writing and shall be made by registered or certified mail, return receipt requested, to:

Judicial Alternatives of Georgia, Inc.

Attn: Kenneth Kight  
901 Bellevue Ave.  
Dublin, Georgia 31021  
Office: (478) 274-0060  
Fax: (478) 274-8168

Municipal Court of Guyton, Georgia

Honorable Grady Reddick  
307 S. Main Street  
Sylvania, Georgia 30467  
Phone: 912-564-7821

The City of Guyton, Georgia  
Attention: City Manager  
310 Central Blvd  
Guyton, Georgia 31312  
Phone: 912-772-3353

IN WITNESS WHEREOF, THE PARTIES HERETO HAVE EXECUTED THIS AGREEMENT ON THE 8<sup>th</sup> DAY OF AUGUST, 2023.

Judicial Alternatives of Georgia, Inc.

By: \_\_\_\_\_  
Name: Kenneth Kight  
Title: CFO, Judicial Alternatives of Georgia, Inc.

The City of Guyton, Georgia

By: \_\_\_\_\_  
Name: Russ Deen  
Title: Mayor, City of Guyton, Georgia

The Municipal Court of Guyton, Georgia

By: \_\_\_\_\_  
Name: Grady Reddick  
Title: Chief Judge, Municipal Court of Guyton, Georgia

# Exhibit A

## SCHEDULE OF FEES

The following are fees paid by the offender to Judicial Alternatives of Georgia, Inc.

<u><i>SERVICE</i></u>	<u><i>COST OF SERVICE</i></u>
Regular Probation Supervision	\$45.00 per month, per offender
Intensive Supervision (Requires minimum of 1 weekly contact)	\$55.00 per month, per offender
Pre-Trial Supervision	\$45.00 per month, per offender
<u><i>ADDITIONAL SERVICES</i></u>	<u><i>COST OF SERVICE</i></u>
Drug Screens (Screens for 8 controlled substances)	\$20.00 per screen
Electronic Monitoring	\$10.00 per day, per offender
Electronic Monitoring w/Intox	\$12.00 per day, per offender

**STATE OF GEORGIA  
CITY OF GUYTON**

**RESOLUTION # 2023-09**

**WHEREAS**, the Mayor and Council of Guyton, Georgia (the “City”), are desirous of entering into an Intergovernmental Agreement with Effingham County, Georgia, whereby the Effingham County Board of Elections and Registration will conduct the City’s municipal elections (the “Agreement”), a copy of which is attached hereto as Exhibit A; and

**WHEREAS**, the Agreement memorializes that Effingham County, through the Effingham County Board of Elections and Registration, shall conduct the City’s municipal elections to occur in 2023, as well as any run-off elections occurring in 2023 to determine the victor of a race originally on the November 2023 ballot; and

**WHEREAS**, the Agreement is not binding on the City until a vote by the Mayor and Council to enter into the Agreement; and

**WHEREAS**, the City of Guyton is desirous of entering into the Agreement because it is in the best interests of the citizenry of the City of Guyton.

**NOW, THEREFORE**, be it resolved by the Mayor and Council of Guyton, Georgia, that the Agreement is approved, and that the Hon. Russ Deen, Mayor of the City of Guyton, Georgia, is fully authorized to: (1) execute all documents necessary to memorialize the Agreement; (2) comply with the terms of the Agreement; and (3) execute all documents in conformity with the Agreement.

**NOW, THEREFORE**, be it resolved by the Mayor and Council of Guyton, Georgia, that the Agreement attached hereto is approved.

Adopted this \_\_\_\_ day of \_\_\_\_\_, 2023.

**CITY OF GUYTON**

\_\_\_\_\_  
Hon. Russ Deen, Mayor

**ATTEST:** \_\_\_\_\_  
Meketa Brown, City Manager

Agreement reviewed and approved by City Attorney:

**OLIVER MANER LLP**

\_\_\_\_\_  
Benjamin M. Perkins, Esq.



**CURRENT YEAR 2023 TAX DIGEST AND FIVE YEAR HISTORY OF LEVY**

	<b>2018</b>	<b>2019</b>	<b>2020</b>	<b>2021</b>	<b>2022</b>	<b>2023</b>
Real and Personal	42,332,941	52,769,251	56,547,038	66,764,835	82,693,791	107,561,714
Motor Vehicles	1,320,220	1,031,040	1,056,680	983,580	858,850	745,520
Mobile Homes	514,349	306,653	567,284	581,366	669,141	644,959
Timber	-	-	-	-	-	-
Heavy duty equipment	-	-	-	-	-	-
Gross Digest	44,167,510	54,106,944	58,171,002	68,329,781	84,221,782	108,952,193
Less: M&O Exemptions	706,797	896,851	1,662,757	2,380,229	2,759,902	3,595,288
Net M&O Digest	43,460,713	53,210,093	56,508,245	65,949,552	81,461,880	105,356,905
Gross M&O Millage	9.865	8.625	8.452	5.368	5.231	4.011
Less: Rollbacks	7.2000	4.9700	4.8860	2.1340	2.3020	1.7110
Net M&O Millage	2.665	3.655	3.566	3.234	2.929	2.300
						<b>PROPOSED</b>
Net Taxes Levied	115,823	194,483	201,508	213,281	238,602	242,321
Net Taxes \$ Increase	3,553	78,660	7,025	11,773	25,321	3,719
Net Taxes % Increase/(Decrease)	3.16%	67.91%	3.61%	5.84%	11.87%	1.56%

CITY OF GUYTON  
STATE OF GEORGIA

ORDINANCE NUMBER 2023-10

AN ORDINANCE OF THE CITY OF GUYTON CREATING THE POSITIONS OF FINANCE CLERK, CODE ENFORCEMENT OFFICER, AND RECEPTIONIST; TO PROVIDE FOR SEVERABILITY; TO PROVIDE AN EFFECTIVE DATE; TO REPEAL ALL ORDINANCES AND RESOLUTIONS AND PARTS THEREOF IN CONFLICT HEREWITH; AND FOR OTHER PURPOSES.

WHEREAS, Section 3.10(a) of the Charter of the City of Guyton, Georgia provides in pertinent part as follows: "...the city council, by ordinance shall prescribe the functions or duties, and establish....all...positions of employment...of the city, as necessary for the proper administration of the affairs and government of this city"; and

WHEREAS, the City Council finds it in the best interest of the City of Guyton to establish the positions of Finance Clerk, Code Enforcement Officer, and Receptionist; and

WHEREAS, it is necessary to prescribe the functions and duties of said position;

NOW THEREFORE, IT IS HEREBY ORDAINED BY THE GOVERNING AUTHORITY OF THE CITY OF GUYTON, GEORGIA IN A MEETING ASSEMBLED AND PURSUANT TO LAWFUL AUTHORITY THEREOF, AS FOLLOWS:

**Section 1. Creation.** The employment position of Finance Clerk is hereby established.

**Section 2. Functions and duties.** The basic functions and duties of the Finance Clerk shall include, but not be limited to: core financial functions of the City including financial management, accounting, reporting, budgeting, payroll, internal auditing and financial record keeping.

**Section 3. Creation.** The employment position of Code Enforcement Officer is hereby established.

**Section 4. Functions and duties.** The basic functions and duties of the Code Enforcement Officer shall include, but not be limited to: conducting comprehensive investigations and inspections, issuing citations, advising property owners, and conducting routine field surveys.

**Section 5. Creation.** The employment position of Receptionist is hereby established.

**Section 6. Functions and duties.** The basic functions and duties of the Receptionist shall include, but not be limited to: perform general administrative and secretarial duties for the City Manager and City Hall.

**Section 7. Repealer.** All ordinances and resolutions and parts thereof in conflict with this ordinance are hereby repealed.

**Section 8. Effective Date.** This ordinance shall become effective immediately upon its adoption by the City Council.

SO ORDAINED, this \_\_ day of August, 2023.

CITY OF GUYTON

---

Russ Deen, Mayor

Attest:

---

Meketa Brown, City Manager

**INTERGOVERNMENTAL AGREEMENT FOR USE AND DISTRIBUTION OF PROCEEDS  
GENERATED BY THE 2023 TRANSPORTATION SPECIAL PURPOSE LOCAL OPTION  
SALES TAX REFERENDUM**

THIS INTERGOVERNMENTAL AGREEMENT ("IGA" or "Agreement") is made and entered into this \_\_\_\_ day of \_\_\_\_\_, 2023 by and between THE BOARD OF COMMISSIONERS OF EFFINGHAM COUNTY, GEORGIA, a political subdivision of the State of Georgia (hereinafter referred to as "Effingham County" or "County"); the CITY OF GUYTON; the CITY OF RINCON; and the CITY OF SPRINGFIELD (hereinafter collectively referred to as the "Cities") incorporated municipalities of the State of Georgia.

**WITNESSETH**

**WHEREAS**, the parties are authorized to enter into this Agreement pursuant to Article IX, Section III, Paragraph I of the Constitution of the State of Georgia of 1983 regarding intergovernmental contracts; and

**WHEREAS**, the parties to this Agreement consist of Effingham County and all qualifying municipalities (hereinafter referred to as the "Cities") located wholly within Effingham County, Georgia; and

**WHEREAS**, the parties anticipate that Effingham County will approve and sign a Resolution authorizing the Effingham County Board of Registrations and Elections to call a referendum on November 7, 2023 (the "Referendum") on the issue of the reimposition of a one percent (1.0%) Transportation Special Purpose Local Option Sales Tax ("TSPLOST" or "Tax") pursuant to O.C.G.A. §48-8-260, et seq., as amended (hereinafter the "Act") to be collected in the special district of Effingham County (the "2023 TSPLOST"); and

**WHEREAS**, a TSPLOST is currently being collected in Effingham County which was approved by a majority of the voters of the County voting in an election held for such purpose on November 3, 2020, which began being collected on April 1, 2021 for a period of time not to exceed five years (the "2020 TSPLOST"), and which tax the County anticipates will cease to be collected on or before \_\_\_\_\_, 2024 due to higher than expected tax collections; and

**WHEREAS**, the parties desire to execute this Agreement to control the distribution and use of the 2023 TSPLOST proceeds received solely by Effingham County and the Cities located within Effingham County; and

**WHEREAS**, the three Cities located wholly within Effingham County have certified they are qualified municipalities and are eligible to receive distributions of the 2023 TSPLOST; and

**WHEREAS**, the parties hereto are interested in serving the needs of the residents of Effingham County by planning and performing transportation projects within the County and the Cities which are parties to this Agreement; and



**WHEREAS**, the parties intend that the transportation projects which are the subject of this Agreement shall benefit the residents of Effingham County and its Cities; and

**WHEREAS**, the County and the Cities located within Effingham County are committed to continue to work together to improve the County's transportation infrastructure; and

**WHEREAS**, on April 11, 2023, the County and the Cities met to discuss the imposition of the 2023 TSPLOST, the rate of said tax, the allocation of the proceeds therefrom, and possible transportation purposes and projects to be funded from the proceeds therefrom, pursuant to O.C.G.A. §48-8-262 (a)(2); and

**WHEREAS**, said meeting between the County and Cities was preceded by a written notice of the date, time, place, and purpose of said meeting being mailed or delivered by the County to the mayor of each of the Cities such that said notice was received by each mayor at least ten days prior to said meeting, pursuant to O.C.G.A. §48-8-262 (a)(2); and

**WHEREAS**, prior to the meeting of the County and the Cities on April 11, 2023, the County determined that a majority of the governing authorities of counties within the applicable regional commission have not passed resolutions calling for the levy of a tax under Article 5 of Chapter 8 of Title 48 of the Official Code of Georgia Annotated; and

**WHEREAS**, the County and the Cities desire to enter into this Agreement for the imposition of the 2023 TSPLOST, the rate thereof, the allocation of the proceeds therefrom, and the identification of the transportation purposes and projects to be funded therefrom; and

**NOW, THEREFORE**, in consideration of the mutual promises and understandings herein made and for other good and valuable consideration, the receipt and sufficiency of which are hereby acknowledged, the parties hereto do consent and agree as follows:

1.

The County makes the following representations and warranties which may bespecifically relied upon by all parties as a basis for entering this Agreement: (a)the County is a political subdivision duly created and organized under the Constitution of the State of Georgia; (b) the governing authority of the County is duly authorized to execute, deliver, and perform this Agreement; (c) this Agreement is a valid, binding, and enforceable obligation of the County;

Each of the Cities makes the following representations and warranties which may be specifically relied upon by all parties as a basis for entering this Agreement: (a) each Municipality is a municipal corporation duly created and organized underthe laws of the State of Georgia; (b) the governing authority of each City is duly authorized to execute,deliver, and perform this Agreement; (c) this Agreement is a valid, binding, and enforceable obligation of eachCity; (d) each City is a qualified municipality as defined in O.C.G.A. § 48-8-110(4); (e) each City is located entirely within the geographic boundaries of thespecial

tax district created in the County.

The County and Cities intend to comply in all respects with the Act. All provisions of this Agreement shall be construed in light of the Act.

2.

This Intergovernmental Agreement is conditioned upon the Referendum to be approved by a majority of the voters of Effingham County to reimpose a TSPLOST of one percent (1.0%). The 2023 TSPLOST shall commence upon the expiration of the 2020 TSPLOST which is currently being collected in Effingham County.

3.

Pursuant to O.C.G.A. § 48-8-267, one percent (1.0%) of the amount of TSPLOST proceeds shall be paid into the General Fund of the State of Georgia ("State") treasury in order to defray the costs of administration of the Georgia Department of Revenue. The remaining ninety-nine percent (99.0%) of the amount collected from the TSPLOST Tax proceeds (hereinafter known as the "net proceeds") beginning as soon as allowed by Georgia law after the expiration of the 2020 TSPLOST and ending five years thereafter, shall be distributed by the State of Georgia to the County and all qualified Cities and shall be allocated to each jurisdiction based on the percentages shown below in Paragraph 4.

4.

Within ten (10) days after the County's monthly receipt from the Department of Revenue of the proceeds of the 2023 TSPLOST, the County shall disburse said proceeds in the following percentages:

City of GUYTON	3.53%
City of RINCON	16.88%
City of SPRINGFIELD	4.18%
EFFINGHAM County	<u>75.41%</u>
Total	100.00%

(A) To facilitate the distribution of net proceeds, the parties agree that the sum of One Hundred Twenty Million and 00/100 Dollars (\$120,000,000.00) shall represent an estimate of the maximum net proceeds to be derived from the 2023 TSPLOST during its five-year term.

(B) The parties agree that no project will be given preference in the funding and distribution process in such a way that the monthly distribution formula is affected.

(C) A list of the transportation purposes and projects proposed to be funded by the proceeds of the 2023 TSPLOST and the estimated or projected dollar amounts for each such transportation purpose and project is set forth on the exhibits attached hereto.

5.

In recognition of the need for transportation improvements across the County and the Cities, the parties agree that the total net proceeds shall be utilized for transportation purposes, as defined in O.C.G.A. § 48-8-260(5) and § 48-8-121.

6.

The County and each City shall approve by resolution a list of projects and purposes ("Transportation Projects and Purposes") to be funded from their allocated net proceeds of the 2023 TSPLOST pursuant to this Agreement, the estimated dollar amounts allocated for each transportation purpose, and the schedule for distribution of funds. The parties acknowledge and agree that 30% of the estimated revenues are being expended on projects that are consistent with the Statewide Strategic Transportation Plan as defined in O.C.G.A. § 32-2-22. The priority and order in which the TSPLOST proceeds will be fully or partially funded is shown in each party's resolution.

7.

If any Transportation Projects and Purposes are geographically located in more than one City or in a City and in an unincorporated area of Effingham County, then the parties involved shall enter into a separate agreement that will define each parties scope and participation in the project, including but not limited to funding and project management.

8.

Except as otherwise provided herein, the 2023 TSPLOST which is the subject of the Referendum shall continue for a period of five years after the expiration of the 2020 TSPLOST, unless otherwise terminated earlier pursuant to O.C.G.A. § 48-8-264(b).

9.

All Transportation Projects included in this Agreement shall be funded in whole or in part from net proceeds from the 2023 TSPLOST. Further, pursuant to O.C.G.A. § 48-8-263 the County shall have the authority to issue general obligation debt in accordance with Article IX, Section V, Paragraph I of the Constitution through the proper officers of the County. Once the authority to issue such debt is so approved by the voters through the Referendum, then such debt may be issued without further approval by the voters pursuant to O.C.G.A. § 48-8-263. Such general obligation debt shall be paid first by a separate fund of the County in which are placed the proceeds received by the County from the tax. Such general obligation debt shall, however, constitute a pledge of the full faith, credit, and taxing power of the County and any liability on such debt which is not satisfied from the proceeds of the tax shall be satisfied from the general fund of the County, or as otherwise provided by law.

The question of whether the voters will approve the 2023 TSPLOST and the issuance of general obligation debt of the County (the "County Bonds") shall be submitted to the voters of Effingham County pursuant to a resolution of the County. Net proceeds of the County Bonds shall be deposited into a special trust account of the County and shall be used for the acquisition, construction and installation of all or a portion of the projects for the County and for the Cities. The County Bonds shall be a general obligation debt of the County. The County shall pay the costs of issuance of the County Bonds and any interest income earned by the County on the investment of the bond proceeds shall be the property of the County. The County shall receive all TSPLOST funds directly from the Georgia Department of Revenue on behalf of the Cities that are using bond funds. The TSPLOST proceeds received in any year pursuant to the tax shall be deposited in a separate fund and first used for paying debt service requirements on the County Bonds for any such year before such proceeds are applied to any of the other purposes.

10.

The net proceeds from the 2023 TSPLOST shall be maintained in the parties' separate accounts and utilized exclusively for the purposes specified in this Agreement. The parties acknowledge that TSPLOST proceeds are not guaranteed. Proceeds received under the amount estimated in the Referendum question shall be allocated in accordance with the percentages set forth in this Agreement and shall be used on the Transportation Projects and Purposes as outlined in the resolutions passed by each party.

11.

Any net proceeds over and above the amount estimated in Paragraph 4(A) of this Agreement shall be allocated in accordance with the percentages set forth in this Agreement and shall be used solely for the transportation purposes listed herein. Each party shall expend its portion of the excess net proceeds from the 2023 TSPLOST Program on the Transportation Projects and Purposes as in the resolutions passed by each party. Should the proceeds generated by the 2023 TSPLOST be insufficient to complete the transportation purposes and projects listed on the exhibits attached hereto, the County and Cities shall have no obligation to pay additional funds from sources other than the 2023 TSPLOST for the completion of any of the same. The County and each of the Cities shall not be obligated to pursue such jurisdiction's Transportation Purposes and Projects set forth on the attached exhibits to the extent that such jurisdiction's share of the proceeds from the 2023 TSPLOST is insufficient to complete all of the same. In such event, the governing body of such jurisdiction may elect to not pursue certain Transportation Projects and Purposes set forth on the attached exhibits for that jurisdiction, or to modify such projects and purposes, beginning with those having the lowest priority, to the extent necessary to remedy such shortfall.

12.

At the end of each party's fiscal year wherein net proceeds from the 2023 TSPLOST are distributed, each party shall cause an audit of the distribution and use of its portion of the net proceeds from the 2023 TSPLOST to be completed. Each party to this Agreement shall pay the cost of each such annual audit that it conducts. Each party shall publish each of its annual audits as required by law.

13.

In addition to the audit required by paragraph 12 of this Agreement, at the end of each calendar year wherein net proceeds from the 2023 TSPLOST are distributed, the Cities and the County shall participate in a joint annual audit of the entire 2023 TSPLOST program approved by the voters in the Referendum. The purpose of this joint annual audit is to ensure compliance with the Resolution that resulted in the call of the 2023 TSPLOST Referendum. Effingham County shall choose the auditor to conduct the annual audit. The cost of such joint annual audit shall be paid for by the County as a county wide service out of the general fund.

14.

Pursuant to O.C.G.A. § 48-8-269.6, not later than December 31 of each year, the County on behalf of itself and the qualified municipalities receiving proceeds from the tax, shall publish annually, in a newspaper of general circulation in the boundaries of each City and the County and in a prominent location on each City's and the County's website, a simple nontechnical report, or consolidated schedule of projects, which shows the following for each Transportation Project or purpose outlined in this Agreement:

- A. Original estimated cost;
- B. Current estimated cost if it is not the original estimated cost;
- C. Amounts expended in prior years;
- D. Amounts expended in the current year;
- E. Any excess proceeds which have not been expended for a project or purpose;
- F. Estimated completion date, and the actual completion cost of a project completed during the current year; and
- G. A statement of what corrective action the City or County intends to implement with respect to each project which is underfunded or behind schedule.

The Cities shall cooperate with the County in compiling the information for the subject report and any expense for said publication shall be paid as a county wide service out of the general fund.

15.

This Agreement constitutes all of the understanding and agreements of whatsoever nature or kind existing between the Parties with respect to distribution and use of the proceeds from the 2023 TSPLOST.

16.

This Agreement shall not be changed or modified except by agreement in writing executed by all Parties hereto.

17.

This Agreement shall be deemed to have been made and shall be construed and interpreted in accordance with the laws of the State of Georgia.

18.

It is agreed that the illegality or invalidity of any term or clause of this Agreement shall not affect the validity of the remainder of the Agreement, and the Agreement shall remain in full force and effect as if such illegal or invalid term or clause were not contained herein.

19.

Each party to this Agreement shall comply with all applicable local, State, and Federal statutes, ordinances, rules and regulations.

20.

No consent or waiver, express or implied, by any party to this Agreement to any breach of any covenant, condition or duty of another party shall be construed as a consent to or waiver of any future breach of the same.

21.

All notices, consents, waivers, directions, requests or other instruments or communications provided for under this Agreement shall be deemed properly given if, and only if, delivered personally or sent by registered or certified United States mail, postage prepaid, as follows:

a. If to Effingham County:

Board of Commissioners of Effingham County, Georgia  
County Manager  
804 South Laurel Street  
Springfield, Georgia 31329

b. If to the City of Guyton:

City of Guyton  
City Manager  
310 Central Boulevard  
Guyton, Georgia 31312

c. If to the City of Rincon:

City of Rincon  
City Manager  
302 South Columbia Avenue  
Rincon, Georgia 31326

d. If to the City of Springfield:  
City of Springfield Georgia  
City Manager  
130 South Laurel Street  
Springfield, Georgia 31329

Any party may at any time change the address where notices are to be sent or the person to whom such notices should be directed by the delivery or mailing to the above persons a notice stating the change.

22.

This Agreement shall become effective as soon as allowed by law after the expiration of the 2020 TSPLOST. If the Referendum concerning the imposition of the 2023 TSPLOST is not approved by a majority of the voters of Effingham County, this Agreement shall expire and shall be of no force and effect after November 7, 2023.

23.

Notwithstanding the parameters of Paragraph 22, this Agreement shall continue in full force and effect until December 31<sup>st</sup> of the year following completion of the last project funded from the net proceeds from the 2023 TSPLOST Program.

24.

This Agreement shall be executed in several counterparts, each of which shall be an original and all of which shall constitute but one and the same instrument.

[SIGNATURES OF COUNTY AND CITIES ON FOLLOWING PAGES]

IN WITNESS WHEREOF, the parties hereto acting through their duly authorized agents have caused this Agreement to be signed, sealed and delivered for final execution by the parties to this agreement.

APPROVED AS TO FORM:

EFFINGHAM COUNTY, GEORGIA

\_\_\_\_\_  
County Attorney

By: \_\_\_\_\_  
Wesley Corbitt, Chairman  
Board of Commissioners

ATTEST:

\_\_\_\_\_  
Clerk



IN WITNESS WHEREOF, the parties hereto acting through their duly authorized agents have caused this Agreement to be signed, sealed and delivered for final execution by the parties to this agreement.

APPROVED AS TO FORM:

CITY OF GUYTON, GEORGIA

\_\_\_\_\_  
City Attorney

By: \_\_\_\_\_  
Russell Deen, Mayor

ATTEST:

\_\_\_\_\_  
Clerk

IN WITNESS WHEREOF, the parties hereto acting through their duly authorized agents have caused this Agreement to be signed, sealed and delivered for final execution by the parties to this agreement.

APPROVED AS TO FORM:

CITY OF RINCON, GEORGIA

\_\_\_\_\_  
City Attorney

By: \_\_\_\_\_  
Kenneth Lee, Mayor

ATTEST:

\_\_\_\_\_  
Clerk

IN WITNESS WHEREOF, the parties hereto acting through their duly authorized agents have caused this Agreement to be signed, sealed and delivered for final execution by the parties to this agreement.

APPROVED AS TO FORM:

CITY OF SPRINGFIELD, GEORGIA

\_\_\_\_\_  
City Attorney

By: \_\_\_\_\_  
Barton Alderman, Mayor

ATTEST:

\_\_\_\_\_  
Clerk

## Guyton TSPLOST Projects List

### Street Resurfacing

Griffin Road	\$ 93,743
Williams Road	\$ 61,232
Magnolia Street	\$224,855
Newborn Street	\$ 27,040
Macedonia Street	\$ 38,964
3rd Avenue	\$ 60,748
5th Avenue	\$ 74,487
6th Avenue	\$ 77,690
7th Avenue	\$ 54,892
Simmons Street	\$ 60,995
Maple Circle	\$ 35,566
Poplar Street	\$ 30,000
Magnolia Street Ext.	\$ 83,387
Other Resurfacing Projects	\$600,000
Trail Extension Phase 1	\$546,212
Recreation Road Construction	\$457,676
Streets and Lanes Equipment	\$300,000
Transportation Drainage Improvements	\$500,000
Pedestrian Improvements	\$500,000
Engineering, Permitting, Surveying, Testing	\$408,002
Total	\$4,236,000

**OPINION OF PROBABLE CONSTRUCTION COST****OPINIONS OF PROBABLE COST**

Since the engineer has no control over the cost of labor, materials, equipment, the Contractor's methods of determining prices, or over competitive bidding or market conditions, the Opinions of Probable Construction Cost provided herein are to be made on the basis of the engineer's experience and qualifications. These opinions represent the engineer's best judgment as a design professional familiar with the construction industry.

**Street Resurfacing**

Section	Description	Total
1	Griffin Road	\$ 93,743.94
2	Williams Road	\$ 61,232.34
3	Magnolia Street	\$ 224,855.47
4	Newborn Street	\$ 27,040.48
5	Macedonia Street	\$ 38,964.23
6	3rd Avenue	\$ 60,748.09
7	5th Avenue	\$ 74,487.79
8	6th Avenue	\$ 77,690.70
9	7th Avenue	\$ 54,892.69
10	Simmons Street	\$ 60,995.67
11	Maple Circle	\$ 35,566.18
12	Poplar Street	\$ 30,000.00
13	Magnolia Street Extension	\$ 83,387.70
<b>TOTAL CONSTRUCTION COST</b>		<b>\$ 923,605.27</b>
14	Engineering	\$ 10,000.00
15	Testing, 5%	\$ 20,000.00
<b>STREETS GRAND TOTAL</b>		<b>\$ 953,605.27</b>

**Other Projects**

16	Trail Extension Phase 1	\$ 546,212.33
17	Construction of 850 ft road with sidewalks on both sides	\$ 457,676.28
<b>TOTAL CONSTRUCTION COST</b>		<b>\$ 1,003,888.61</b>
18	Engineering, Permitting, Surveying, 15%	\$ 150,583.00
<b>OTHER PROJECTS GRAND TOTAL</b>		<b>\$ 1,154,471.61</b>



**TO:** City of Guyton  
**FROM:** Zach Tatum, Machine Sales Rep, Cell: 912-237-0830  
**DATE:** 4/14/23

**SUBJECT:** Cat 415 Backhoe **BUDGET QUOTE**

Yancey Bros. Co. appreciates the opportunity to quote your equipment needs. See the below quotation per your request. Please let me know if you have any other questions.

**CATERPILLAR 415 Backhoe**

**Includes: 4WD, Standard Shift Transmission, 14ft Reach on Rear Boom, 24in Tooth Bucket on rear, Quick Coupler Equipped with 1.3yd Bucket and Pallet Forks on Front.**

**Warranty: 24 Month / 2000 Hr Premier Warranty Included with Machine.**

**Additional Warranty can be purchased upon request.**

**SALES PRICE**

**\$124,559**

This quotation is for your information only and is not to be considered binding until both parties have executed a signed Equipment Order Form. Sale and lease pricing, terms and conditions will be governed by the Agreement.



# Cat<sup>®</sup> 415

## BACKHOE LOADER

The Cat<sup>®</sup> 415 Backhoe Loader delivers exceptional performance, increased fuel efficiency, superior hydraulic system and an updated operator station. The 415 features the following:

- **Ergonomic Operator Station** – Ample legroom inside the cab makes rotating the seat simple. The air suspension seat provides comfort to the operator while roading.
- **Joystick Controls** – Pilot joysticks are available for additional operator comfort, reduced fatigue and increased productivity. New Proportional Thumb Rollers on the Pilot Joysticks places E-Stick and Rear Auxiliary Controls at the operator's fingertips.
- **Load Sensing Hydraulics** – The Cat Backhoe Loader's load sensing piston pump provides full hydraulic lifting and digging forces at any engine speed. Variable flow pump matches hydraulic power to work demands.
- **Machine Performance** – The proven Cat C3.6 engine delivers solid performance, meets U.S. EPA Tier 4 Final/EU Stage V emission standards, and requires no diesel exhaust fluid (DEF).
- **Machine Versatility** – The all new Integrated Tool Carrier (IT Coupler) for Single Tilt Loader Arm configurations are available from the factory or for simple field installation. The Cat Backhoe Loader with Integrated Tool Carrier (IT Coupler) will be the most versatile machine on the job site providing quick connection to a variety of Cat Attachments.
- **Cat Attachments** – A large portfolio of Backhoe Loader Attachments, including but not limited to, Quick Couplers, Thumbs, assorted Buckets, and Brooms are available from the factory or for field installation. Cat Backhoe Loaders will be "Dirt Ready" upon delivery.

## Specifications

### Engine

Engine	C3.6 55 kW (74 hp) Electronic Turbo Intercooled	
Ratings at 2,200 rpm		
Gross Power SAE J1995	56 kW	75 hp
Gross Power ISO 14396	55 kW	74 hp
Net Power Rating at 2,200 rpm		
SAE J1349	52 kW	70 hp
ISO 9249	52 kW	69 hp
Net Peak Power Rating @ 2,200 rpm		
SAE J1349	52 kW	70 hp
ISO 9249	53 kW	71 hp
Dimensions		
Bore	98 mm	3.86 in
Stroke	120 mm	4.72 in
Displacement	3.6 L	220 in <sup>3</sup>
Torque Rise (net) at 1,400 rpm	85%	
SAE J1349 Net	418 N·m	308 lb·ft
Power Rating Conditions		
No de-rating required up to	3048 m	10,000 ft

- Engine meets U.S. EPA Tier 4 Final/EU Stage V emission standards.

### Weights\*

Operating Weight* (estimated)	7384 kg	16,279 lb
Operating Weight (maximum) (ROPS capacity)	11 000 kg	24,251 lb
Operating Weight (minimum)	6997 kg	15,426 lb
Cab, ROPS/FOPS	139 kg	306 lb
Auto-Shift Transmission	122 kg	269 lb
Ride Control	15 kg	33 lb
Air Conditioning	45 kg	99 lb
All-Wheel Drive	STD	STD
MP bucket (0.96 m <sup>3</sup> /1.25 yd <sup>3</sup> )		
with fold-over forks	915 kg	2,017 lb
without fold-over forks	745 kg	1,642 lb
Loader QC	245 kg	540 lb
Extendible Stick (excludes ft. counterweight)	278 kg	613 lb
Counterweights, base	115 kg	256 lb
Stackable, one	240 kg	529 lb
Maximum	460 kg	1,014 lb

\*Machine configuration: standard stick hoe, OROPS canopy, 4WD standard shift transmission, 0.96 m<sup>3</sup> (1.25 yd<sup>3</sup>) GP (General Purpose) loader bucket, 610 mm (24 in) standard duty hoe bucket, front 340/80-18 and rear 500/70-24 tires, 240 kg (530 lb) counterweight, 80 kg (176 lb) operator, full fuel tank.



# 415 Backhoe Loader

## Transmission\*

### Power Shuttle Transmission – Standard

Forward – 1st	5.5 km/h	3.4 mph
2nd	9.1 km/h	5.7 mph
3rd	21 km/h	13 mph
4th	38 km/h	23 mph
Reverse – 1st	5.5 km/h	3.4 mph
2nd	9.1 km/h	5.7 mph
3rd	21 km/h	13 mph
4th	38 km/h	23 mph

### Power-Shift Transmission – Optional

Forward – 1st	5.9 km/h	3.7 mph
2nd	9.4 km/h	5.8 mph
3rd	20 km/h	12 mph
4th	40 km/h	25 mph
Reverse – 1st	5.9 km/h	3.7 mph
2nd	12 km/h	7.6 mph
3rd	27 km/h	17 mph

\*Travel speeds of backhoe loader at full throttle, when equipped with 500/70-24 rear tires.

## Axle Ratings

### Front Axle, AWD

Static	23 500 kg	51,808 lb
Dynamic	9000 kg	19,841 lb

### Rear Axle

Static	26 500 kg	58,422 lb
Dynamic	10 000 kg	22,046 lb

## Hydraulic System

Type	Closed Center	
Pump Type	Variable-flow, Axial Piston	
Pump Capacity @ 2,200 rpm	132 L/min	34.9 gal/min
System Pressure		
Backhoe	23 000 kPa	3,336 psi
Loader	23 000 kPa	3,336 psi

## Steering

Type	Front Wheel Steering	
Power Steering	Hydrostatic	
One Double-Acting Cylinder		
Bore	65 mm	2.6 in
Stroke	106 mm	4.2 in
Rod Diameter	40 mm	1.6 in
Axle Oscillation	11°	
Turning Circle – (inner wheel not braked)		
Outside Front Wheels	8.205 m	26'11"
Outside Widest Loader Bucket	10.745 m	35'3"

## Service Refill Capacities

Cooling System with Air Conditioning	18.0 L	4.8 gal
Fuel Tank	160.0 L	42.3 gal
Engine Oil with Filter	9.0 L	2.4 gal
Transmission – Power Shuttle		
AWD	18.0 L	4.8 gal
Transmission – Power Shift		
AWD	19.0 L	5.0 gal
Rear Axle	16.0 L	4.2 gal
Planetaries	1.7 L	0.4 gal
Front Axle (AWD)	11.0 L	2.9 gal
Planetaries	0.7 L	0.2 gal
Hydraulic System	95.0 L	25.1 gal
Hydraulic Tank	42.0 L	11.1 gal

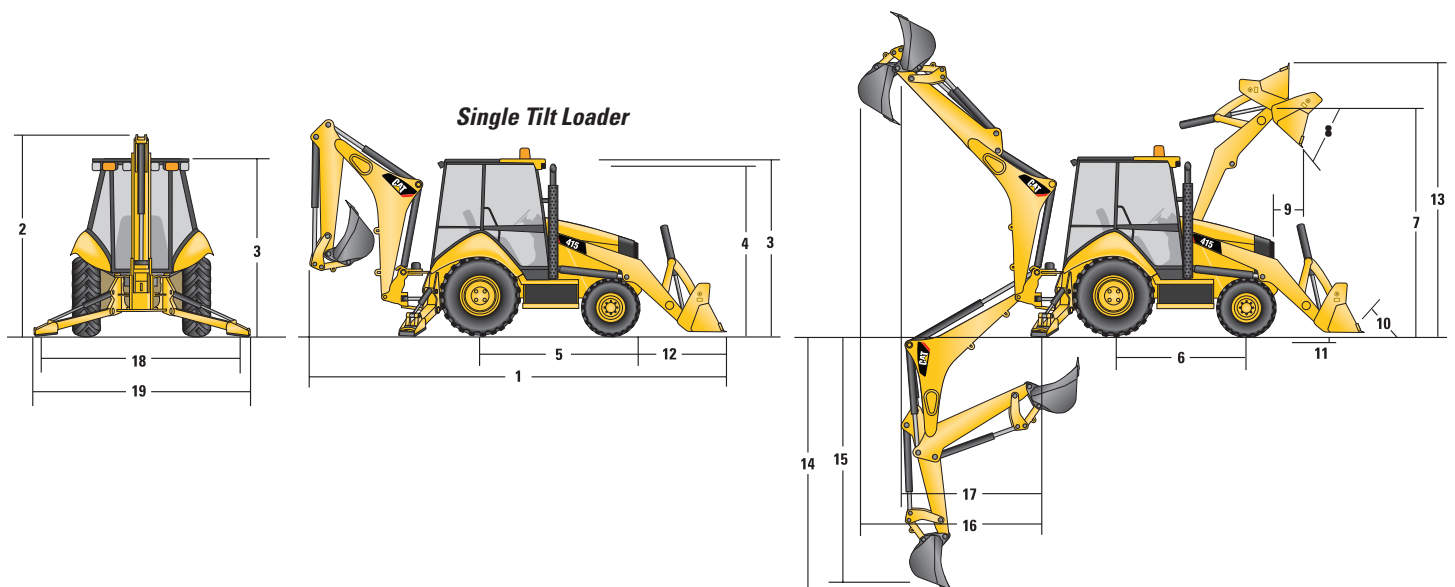



## Dimensions

Machine configuration: standard stick hoe, OROPS canopy, 4WD standard shift transmission, 0.96 m<sup>3</sup> (1.25 yd<sup>3</sup>) GP loader bucket, 610 mm (24 in) standard duty hoe bucket, front 340/80-18 and rear 500/70-24 tires, 240 kg (530 lb) counterweight, 80 kg (176 lb) operator, full fuel tank.

### Single Tilt with Pin-On Buckets

	0.76 m <sup>3</sup> (1.0 yd <sup>3</sup> ) GP	0.96 m <sup>3</sup> (1.25 yd <sup>3</sup> ) GP	1.0 m <sup>3</sup> (1.31 yd <sup>3</sup> ) GP	1.07 m <sup>3</sup> (1.40 yd <sup>3</sup> ) GP	1.0 m <sup>3</sup> (1.31 yd <sup>3</sup> ) MP	1.07 m <sup>3</sup> (1.40 yd <sup>3</sup> ) MP
1 Overall Length (loader on ground) – S-Stick – mm (ft/in)	7018 (23'0")	7131 (23'5")	7086 (23'3")	7151 (23'6")	7059 (23'2")	7059 (23'2")
Overall Length (loader on ground) – E-Stick – mm (ft/in)	7024 (23'1")	7136 (23'5")	7091 (23'3")	7157 (23'6")	7064 (23'2")	7064 (23'2")
Overall Transport Length – S-Stick – mm (ft/in)	7079 (23'3")	7162 (23'6")	7128 (23'5")	7199 (23'7")	7129 (23'5")	7129 (23'5")
Overall Transport Length – E-Stick – mm (ft/in)	7084 (23'3")	7188 (23'7")	7134 (23'5")	7205 (23'8")	7135 (23'5")	7135 (23'5")
2 Overall Transport Height – Standard Stick – mm (ft/in)	3646 (12'0")	3646 (12'0")	3646 (12'0")	3646 (12'0")	3646 (12'0")	3646 (12'0")
Overall Transport Height – Extendible Stick – mm (ft/in)	3666 (12'0")	3666 (12'0")	3666 (12'0")	3666 (12'0")	3666 (12'0")	3666 (12'0")
Overall Width – mm (ft/in)	2248 (7'5")	2248 (7'5")	2248 (7'5")	2248 (7'5")	2248 (7'5")	2248 (7'5")
3 Height to Top of Cab/Canopy – mm (ft/in)	2815 (9'3")	2815 (9'3")	2815 (9'3")	2815 (9'3")	2815 (9'3")	2815 (9'3")
4 Height to Top of Exhaust Stack – mm (ft/in)	2720 (8'11")	2720 (8'11")	2720 (8'11")	2720 (8'11")	2720 (8'11")	2720 (8'11")
Height to Loader Hinge Pin (transport) – mm (ft/in)	379 (1'3")	378 (1'3")	378 (1'3")	422 (1'5")	420 (1'5")	420 (1'5")
Ground Clearance (LH step) – mm (ft/in)	316 (1'0")	316 (1'0")	316 (1'0")	316 (1'0")	316 (1'0")	316 (1'0")
Ground Clearance (AWD guard) – mm (ft/in)	312 (1'0")	312 (1'0")	312 (1'0")	312 (1'0")	312 (1'0")	312 (1'0")
Ground Clearance (485 kg/1,070 lb counterweight) – mm (ft/in)	289 (0'11")	289 (0'11")	289 (0'11")	289 (0'11")	289 (0'11")	289 (0'11")
5 Rear Axle Centerline to Front Grill – mm (ft/in)	2706 (8'11")	2706 (8'11")	2706 (8'11")	2706 (8'11")	2706 (8'11")	2706 (8'11")
Front Wheel Tread Gauge – mm (ft/in)	1895 (6'3")	1895 (6'3")	1895 (6'3")	1895 (6'3")	1895 (6'3")	1895 (6'3")
Rear Wheel Tread Gauge – mm (ft/in)	1728 (5'8")	1728 (5'8")	1728 (5'8")	1728 (5'8")	1728 (5'8")	1728 (5'8")
6 Wheelbase – mm (ft/in)	2200 (7'3")	2200 (7'3")	2200 (7'3")	2200 (7'3")	2200 (7'3")	2200 (7'3")

### Single Tilt Loader with Quick Coupler

	0.96 m <sup>3</sup> (1.25 yd <sup>3</sup> ) GP	1.0 m <sup>3</sup> (1.31 yd <sup>3</sup> ) GP	1.15 m <sup>3</sup> (1.50 yd <sup>3</sup> ) GP	1.0 m <sup>3</sup> (1.31 yd <sup>3</sup> ) MP	1.07 m <sup>3</sup> (1.40 yd <sup>3</sup> ) MP
1 Overall Length (loader on ground) – S-Stick – mm (ft/in)	7312 (24'0")	7268 (23'10")	7310 (24'0")	7219 (23'8")	7219 (23'8")
Overall Length (loader on ground) – E-Stick – mm (ft/in)	7318 (24'0")	7273 (23'10")	7315 (24'0")	7225 (23'8")	7225 (23'8")
Overall Transport Length – S-Stick – mm (ft/in)	7289 (23'11")	7255 (23'10")	7287 (23'11")	7217 (23'8")	7217 (23'8")
Overall Transport Length – E-Stick – mm (ft/in)	7295 (23'11")	7261 (23'10")	7293 (23'11")	7223 (23'8")	7223 (23'8")
2 Overall Transport Height – Standard Stick – mm (ft/in)	3646 (12'0")	3646 (12'0")	3646 (12'0")	3646 (12'0")	3646 (12'0")
Overall Transport Height – Extendible Stick – mm (ft/in)	3666 (12'0")	3666 (12'0")	3666 (12'0")	3666 (12'0")	3666 (12'0")
Overall Width – mm (ft/in)	2248 (7'5")	2248 (7'5")	2248 (7'5")	2248 (7'5")	2248 (7'5")
3 Height to Top of Cab/Canopy – mm (ft/in)	2815 (9'3")	2815 (9'3")	2815 (9'3")	2815 (9'3")	2815 (9'3")
4 Height to Top of Exhaust Stack – mm (ft/in)	2720 (8'11")	2720 (8'11")	2720 (8'11")	2720 (8'11")	2720 (8'11")
Height to Loader Hinge Pin (transport) – mm (ft/in)	345 (1'2")	346 (1'2")	346 (1'2")	344 (1'2")	344 (1'2")
Ground Clearance (LH step) – mm (ft/in)	316 (1'0")	316 (1'0")	316 (1'0")	316 (1'0")	316 (1'0")
Ground Clearance (AWD guard) – mm (ft/in)	312 (1'0")	312 (1'0")	312 (1'0")	312 (1'0")	312 (1'0")
Ground Clearance (485 kg/1,070 lb counterweight) – mm (ft/in)	289 (0'11")	289 (0'11")	289 (0'11")	289 (0'11")	289 (0'11")
5 Rear Axle Centerline to Front Grill – mm (ft/in)	2706 (8'11")	2706 (8'11")	2706 (8'11")	2706 (8'11")	2706 (8'11")
Front Wheel Tread Gauge – mm (ft/in)	1895 (6'3")	1895 (6'3")	1895 (6'3")	1895 (6'3")	1895 (6'3")
Rear Wheel Tread Gauge – mm (ft/in)	1728 (5'8")	1728 (5'8")	1728 (5'8")	1728 (5'8")	1728 (5'8")
6 Wheelbase – mm (ft/in)	2200 (7'3")	2200 (7'3")	2200 (7'3")	2200 (7'3")	2200 (7'3")

# 415 Backhoe Loader

## Dimensions

Machine configuration: standard stick hoe, OROPS canopy, 4WD standard shift transmission, 0.96 m<sup>3</sup> (1.25 yd<sup>3</sup>) GP loader bucket, 610 mm (24 in) standard duty hoe bucket, front 340/80-18 and rear 500/70-24 tires, 240 kg (530 lb) counterweight, 80 kg (176 lb) operator, full fuel tank.

## Loader Bucket Dimensions and Performance

	Pin-On Buckets											
	0.76 m <sup>3</sup> (1.0 yd <sup>3</sup> ) GP		0.96 m <sup>3</sup> (1.25 yd <sup>3</sup> ) GP		1.0 m <sup>3</sup> (1.31 yd <sup>3</sup> ) GP		1.07 m <sup>3</sup> (1.40 yd <sup>3</sup> ) GP		1.0 m <sup>3</sup> (1.31 yd <sup>3</sup> ) MP		1.07 m <sup>3</sup> (1.40 yd <sup>3</sup> ) MP	
Capacity (SAE rated) – m <sup>3</sup> (yd <sup>3</sup> )	0.76	(1.0)	0.96	(1.26)	1.00	(1.31)	1.07	(1.40)	1.00	(1.31)	1.07	(1.40)
Overall Bucket Width – mm (in)	2262	(89)	2262	(89)	2406	(95)	2262	(89)	2279	(90)	2425	(95)
Lift Capacity at Maximum Height – kg (lb)	3053	(6,730)	2962	(6,530)	2967	(6,541)	2900	(6,393)	2736	(6,032)	2724	(6,005)
Lift Breakout Force – N (lbf)	48 282	(10,854)	45 673	(10,267)	46 360	(10,422)	45 164	(10,153)	44 481	(9,999)	44 385	(9,978)
Tilt Breakout Force – N (lbf)	54 304	(12,207)	45 719	(10,278)	48 604	(10,926)	46 676	(10,493)	51 462	(11,569)	51 386	(11,551)
Tipping Load at Breakout Point – kg (lb)	6969	(15,363)	6486	(14,298)	6640	(14,638)	6387	(14,081)	6515	(14,363)	6505	(14,342)
7 Maximum Hinge Pin Height – mm (ft/in)	3488	(11'5")	3488	(11'5")	3488	(11'5")	3488	(11'5")	3488	(11'5")	3488	(11'5")
8 Dump Angle at Full Height – degrees	44°		44°		44°		44°		44°		44°	
Dump Height at Maximum Angle – mm (ft/in)	2837	(9'4")	2758	(9'1")	2790	(9'2")	2736	(9'0")	2803	(9'2")	2803	(9'2")
9 Dump Reach at Maximum Angle – mm (ft/in)	726	(2'5")	807	(2'8")	774	(2'6")	773	(2'6")	722	(2'4")	722	(2'4")
10 Maximum Bucket Rollback at Ground Level – degrees	36°		36°		36°		37°		37°		37°	
11 Digging Depth – mm (ft/in)	70	(0'3")	70	(0'3")	70	(0'3")	110	(0'4")	97	(0'4")	97	(0'4")
Maximum Grading Angle – degrees	116°		113°		114°		114°		116°		116°	
Width of Dozer Cutting Edge – mm (ft/in)	N/A		N/A		N/A		N/A		2262	(7'5")	2406	(7'11")
12 Grill to Bucket Cutting Edge, Carry Position – mm (ft/in)	1397	(4'7")	1480	(4'10")	1447	(4'9")	1518	(5'0")	1447	(4'9")	1447	(4'9")
13 Maximum Operating Height – mm (ft/in)	4206	(13'10")	4356	(14'3")	4354	(14'3")	4366	(14'4")	4378	(14'4")	4407	(14'6")
Jaw Opening Maximum – mm (ft/in)	N/A		N/A		N/A		N/A		843	(2'9")	843	(2'9")
Bucket Jaw Clamping Force – N (lbf)	N/A		N/A		N/A		N/A		37 113	(8,343)	37 214	(8,366)
Weight (does not include teeth or forks) – kg (lb)	384	(847)	451	(994)	462	(1,019)	473	(1,043)	745	(1,642)	774	(1,706)

	Single Tilt Loader with Quick Coupler									
	0.96 m <sup>3</sup> (1.25 yd <sup>3</sup> ) GP		1.0 m <sup>3</sup> (1.31 yd <sup>3</sup> ) GP		1.15 m <sup>3</sup> (1.50 yd <sup>3</sup> ) GP		1.0 m <sup>3</sup> (1.31 yd <sup>3</sup> ) MP		1.07 m <sup>3</sup> (1.40 yd <sup>3</sup> ) MP	
Capacity (SAE rated) – m <sup>3</sup> (yd <sup>3</sup> )	0.96	(1.26)	1.00	(1.31)	1.15	(1.50)	1.00	(1.31)	1.07	(1.40)
Overall Bucket Width – mm (in)	2262	(89)	2406	(95)	2406	(95)	2279	(90)	2425	(95)
Lift Capacity at Maximum Height – kg (lb)	2579	(5,686)	2579	(5,686)	2546	(5,612)	2438	(5,375)	2402	(5,296)
Lift Breakout Force – N (lbf)	40 911	(9,197)	41 450	(9,318)	40 608	(9,129)	40 289	(9,057)	40 029	(8,999)
Tilt Breakout Force – N (lbf)	37 640	(8,462)	39 574	(8,896)	37 351	(8,396)	40 227	(9,043)	40 055	(9,004)
Tipping Load at Breakout Point – kg (lb)	5721	(12,612)	5841	(12,876)	5696	(12,556)	5811	(12,812)	5787	(12,757)
7 Maximum Hinge Pin Height – mm (ft/in)	3488	(11'5")	3488	(11'5")	3488	(11'5")	3488	(11'5")	3488	(11'5")
8 Dump Angle at Full Height – degrees	44°		44°		44°		44°		44°	
Dump Height at Maximum Angle – mm (ft/in)	2623	(8'7")	2654	(8'9")	2625	(8'7")	2690	(8'10")	2690	(8'10")
9 Dump Reach at Maximum Angle – mm (ft/in)	887	(2'11")	855	(2'10")	886	(2'11")	832	(2'9")	832	(2'9")
10 Maximum Bucket Rollback at Ground Level – degrees	37°		37°		37°		37°		37°	
11 Digging Depth – mm (ft/in)	111	(0'4")	111	(0'4")	110	(0'4")	101	(0'4")	101	(0'4")
Maximum Grading Angle – degrees	109°		110°		109°		111°		111°	
Width of Dozer Cutting Edge – mm (ft/in)	N/A		N/A		N/A		2262	(7'5")	2406	(7'11")
12 Grill to Bucket Cutting Edge, Carry Position – mm (ft/in)	1607	(5'3")	1573	(5'2")	1605	(5'3")	1535	(5'0")	1535	(5'0")
13 Maximum Operating Height – mm (ft/in)	4439	(14'7")	4406	(14'5")	4484	(14'9")	4476	(14'8")	4531	(14'10")
Jaw Opening Maximum – mm (ft/in)	N/A		N/A		N/A		843	(2'9")	843	(2'9")
Bucket Jaw Clamping Force – N (lbf)	N/A		N/A		N/A		37 136	(8,348)	37 237	(8,371)
Weight (does not include teeth or forks) – kg (lb)	447	(985)	457	(1,008)	481	(1,060)	724	(1,596)	753	(1,660)

## Dimensions

Machine configuration: standard stick hoe, OROPS canopy, 4WD standard shift transmission, 0.96 m<sup>3</sup> (1.25 yd<sup>3</sup>) GP loader bucket, 610 mm (24 in) standard duty hoe bucket, front 340/80-18 and rear 500/70-24 tires, 240 kg (530 lb) counterweight, 80 kg (176 lb) operator, full fuel tank.

## Backhoe Dimensions and Performance

	Standard Stick		E-Stick Retracted		E-Stick Extended	
<b>14</b> Digging Depth, SAE (max.) – mm (ft/in)	4277	(14'0")	4317	(14'2")	5371	(17'7")
<b>15</b> Digging Depth, 2438 mm (8 ft) Flat Bottom – mm (ft/in)	3899	(12'9")	3942	(12'11")	5072	(16'8")
Digging Depth, 610 mm (2 ft) Flat Bottom – mm (ft/in)	4239	(13'11")	4279	(14'0")	5334	(17'6")
Reach from Rear Axle Centerline at Ground Line – mm (ft/in)	6690	(21'11")	6726	(22'1")	7731	(25'4")
<b>16</b> Reach from Swing Pivot at Ground Line – mm (ft/in)	5600	(18'4")	5636	(18'6")	6641	(21'9")
Maximum Operating Height – mm (ft/in)	5601	(18'5")	5625	(18'5")	6368	(20'11")
Loading Height – mm (ft/in)	3710	(12'2")	3667	(12'0")	4238	(13'11")
<b>17</b> Loading Reach – mm (ft/in)	1841	(6'0")	1928	(6'4")	2846	(9'4")
Swing Arc	180°		180°		180°	
Bucket Rotation	205°		204°		204°	
<b>18</b> Stabilizer Spread, Operating Position (center) – mm (ft/in)	3310	(10'10")	3310	(10'10")	3310	(10'10")
Stabilizer Spread, Operating Position (outside) – mm (ft/in)	3770	(12'4")	3770	(12'4")	3770	(12'4")
Stabilizer Spread, Transport Position – mm (ft/in)	2322	(7'7")	2322	(7'7")	2322	(7'7")
Bucket Dig Force – N (lbf)	59 119	(13,291)	58 289	(13,104)	58 289	(13,104)
Stick Dig Force – N (lbf)	32 374	(7,278)	32 417	(7,288)	23 800	(5,350)

## Dimensions with Forks/Material Handling Arm

Fork Tine Length	1070 mm (3'6")		1220 mm (4'0")		1370 mm (4'10")	
Operating Load (SAE J1197) – kg (lb)	1758	(3,875)	1684	(3,713)	1615	(3,559)
SAE Load Center – mm (in)	535	(1'9")	610	(2'0")	685	(2'3")
Operating Load (CEN 474-4) – kg (lb)	1786	(3,938)	1771	(3,904)	1754	(3,867)
CEN Load Center – mm (ft/in)	500	(1'8")	500	(1'8")	500	(1'8")
Overall Length (A) (forks on ground) – mm (ft/in)	7647	(25'1")	7797	(25'7")	7946	(26'1")
Reach at Ground (from grill to heel of fork) – mm (ft/in)	939	(3'1")	939	(3'1")	938	(3'1")
Maximum Reach (from grill to heel of fork) – mm (ft/in)	1524	(5'0")	1524	(5'0")	1524	(5'0")
Fork Height at Maximum Reach – mm (ft/in)	1619	(5'4")	1619	(5'4")	1619	(5'4")
Reach at Maximum Height (from grill to heel of fork) – mm (ft/in)	749	(2'5")	749	(2'5")	749	(2'5")
Maximum Fork Height – mm (ft/in)	3418	(11'3")	3418	(11'3")	3418	(11'3")
Maximum Fork Depth (below ground level) – mm (ft/in)	-38	(-1'11")	-38	(-1'10")	-39	(-1'10")

Material Handling Arm Position	Retracted		Mid-Position		Extended	
Operating Load (SAE J1197 and CEN 474-4) – kg (lb)*	1091	(2,404)	733	(1,615)	531	(1,171)
Overall Length, Maximum – mm (ft/in)	8903	(29'3")	9903	(32'6")	10 901	(35'9")
Reach at Maximum Depth (from machine nose) – mm (ft/in)	544	(1'9")	550	(1'10")	557	(1'10")
Maximum Depth – mm (ft/in)	2618	(8'7")	3618	(11'10")	4616	(15'2")
Maximum Reach (from machine nose) – mm (ft/in)	3221	(10'7")	4221	(13'10")	5219	(17'1")
Height at Maximum Reach – mm (ft/in)	1118	(3'8")	1124	(3'8")	1130	(3'8")
Reach at Maximum Height (from machine nose) – mm (ft/in)	1783	(5'10")	2473	(8'1")	3161	(10'4")
Maximum Height – mm (ft/in)	4445	(14'7")	5169	(16'11")	5891	(19'4")

\*These numbers are hydraulically limited.

# 415 Backhoe Loader

## Backhoe Lift Capacity

### Cat 415 Standard Stick

Boom Lifting	kg	lb
1	1334	2,941
2	1426	3,144
3	1407	3,101
4	1353	2,983
5	1292	2,849
6	1232	2,716
7	1174	2,589
8	1120	2,469
9	1069	2,358
10	1022	2,254
11	979	2,158
12	939	2,071
13	905	1,996
14	885	1,952
15	916	2,019
<b>Stick Lifting</b>		
16	1568	3,456
17	1916	4,224
18	2328	5,133
19	2436	5,371
20	2884	6,358
21	3540	7,805

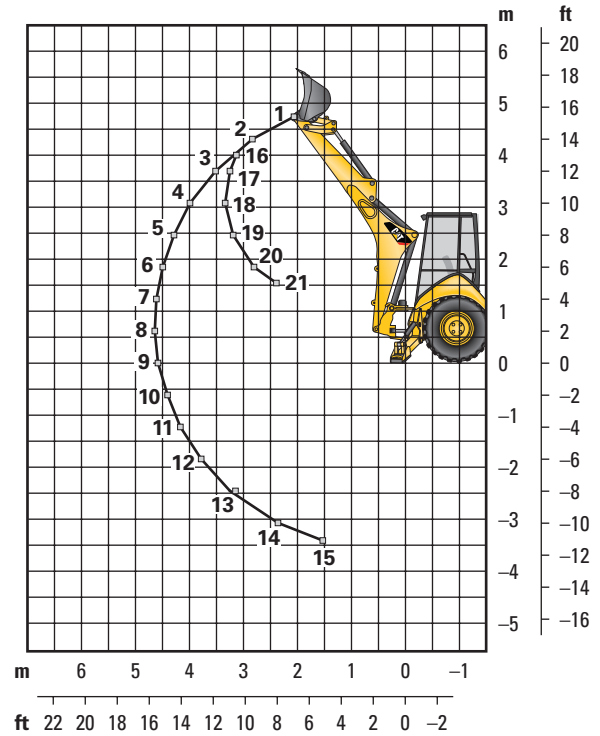

### Cat 415 Extendible Stick – Retracted

Boom Lifting	kg	lb
1	1157	2,551
2	1235	2,722
3	1208	2,664
4	1153	2,541
5	1091	2,404
6	1029	2,269
7	970	2,139
8	915	2,017
9	863	1,902
10	814	1,794
11	768	1,692
12	725	1,597
13	684	1,509
14	650	1,432
15	647	1,427
<b>Stick Lifting</b>		
16	1423	3,138
17	1754	3,866
18	2128	4,692
19	2226	4,908
20	2629	5,796
21	3189	7,030
22	0	0

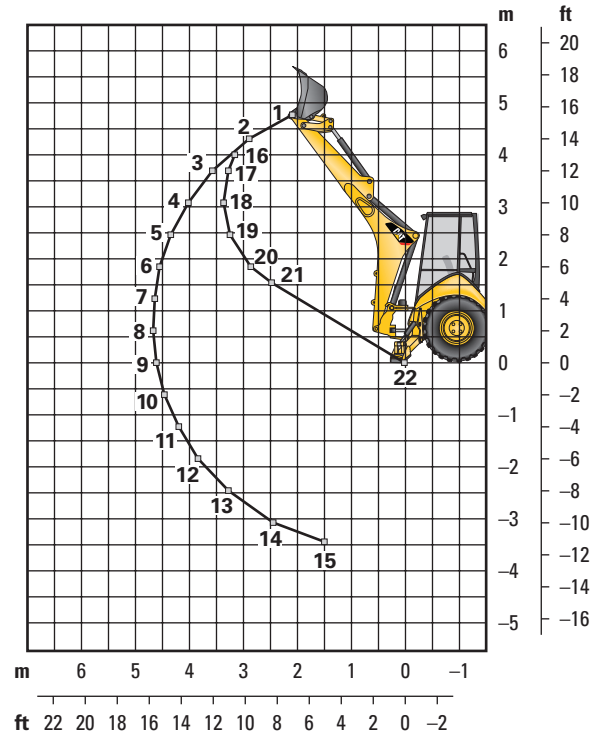

Lift capacities are over-end values calculated according to SAE J31. Values are 87% of the maximum lift force available. Machine equipped with AWD, OROPS, 0.96 m<sup>3</sup> (1.25 yd<sup>3</sup>) general purpose bucket and no counterweight. Extendible stick includes 460 kg (1,015 lb) counterweight.

## Backhoe Lift Capacity

### Cat 415 Extendible Stick – Extended

<b>Boom Lifting</b>			
	<b>kg</b>	<b>lb</b>	
1	640	1,412	
2	771	1,700	
3	802	1,767	
4	799	1,761	
5	782	1,724	
6	759	1,673	
7	733	1,616	
8	706	1,557	
9	680	1,498	
10	654	1,442	
11	630	1,388	
12	607	1,339	
13	587	1,295	
14	571	1,259	
15	561	1,237	
16	566	1,248	
17	648	1,429	
18	867	1,911	
<b>Stick Lifting</b>			
19	597	1,316	
20	767	1,692	
21	1008	2,222	
22	1178	2,597	
23	1322	2,915	
24	1479	3,260	
25	1711	3,773	
26	2305	5,082	
27	3506	7,730	

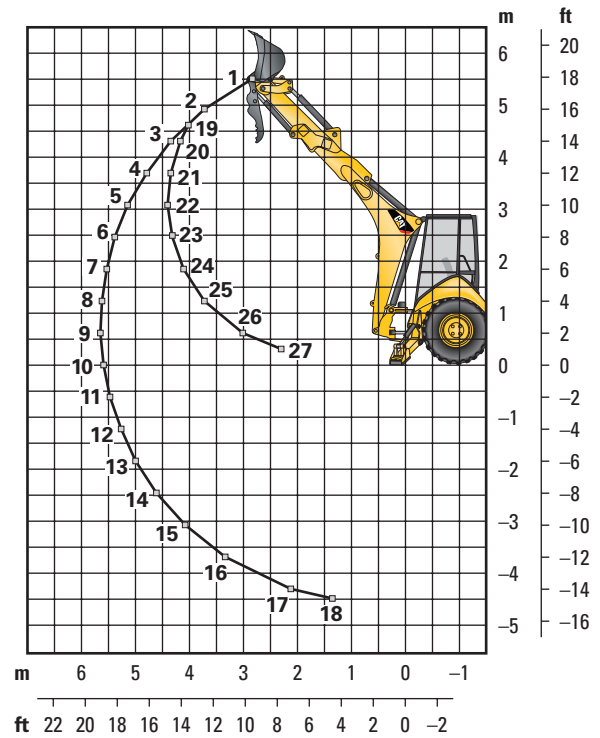

Lift capacities are over-end values calculated according to SAE J31. Values are 87% of the maximum lift force available. Machine equipped with AWD, DROPS, 0.96 m<sup>3</sup> (1.25 yd<sup>3</sup>) general purpose bucket and no counterweight. Extendible stick includes 460 kg (1,015 lb) counterweight.

# 415 Backhoe Loader

## Counterweights (Minimum Counterweight Recommendations)

Standard Stick Loader Bucket	Pin-On Bucket		Loader QC	
	kg	lb	kg	lb
GP	115	255	0	0
MP	0	0	0	0
Forks	N/A	N/A	0	0
Material Handling Arm	N/A	N/A	0	0

Extendible Stick Loader Bucket	Pin-On Bucket		Loader QC	
	kg	lb	kg	lb
GP	460	1,015	240	530
MP	115	255	0	0
Forks	N/A	N/A	240	530
Material Handling Arm	N/A	N/A	240	530

## Backhoe Buckets (With weld on adapters and pin-on teeth)

### Standard Duty

Width		Rated Capacity		Weight		No. of Teeth
mm	in	L	ft <sup>3</sup>	kg	lb	
305	12	80	2.8	111	245	3
457	18	120	4.2	122	268	4
610	24	180	6.4	141	311	5
762	30	230	8.1	157	345	5
914	36	290	10.2	176	388	6

### Heavy Duty

Width		Rated Capacity		Weight		No. of Teeth
mm	in	L	ft <sup>3</sup>	kg	lb	
305	12	80	2.8	121	266	3
406	16	110	3.9	128	282	3
457	18	120	4.2	135	299	4
610	24	180	6.4	160	353	5
762	30	230	8.1	177	391	5
914	36	290	10.2	201	443	6

### Soil Excavation

Width		Rated Capacity		Weight		No. of Teeth
mm	in	L	ft <sup>3</sup>	kg	lb	
457	18	180	6.4	155	341	4
610	24	240	8.5	182	402	5
762	30	320	11.3	206	454	5
914	36	380	13.4	233	513	6

### Rock

Width		Rated Capacity		Weight		No. of Teeth
mm	in	L	ft <sup>3</sup>	kg	lb	
305	12	70	2.5	127	279	3
457	18	130	4.6	146	322	4
610	24	200	7.1	174	384	5
762	30	270	9.5	197	434	5
914	36	330	11.7	224	493	6

### Coral

Width		Rated Capacity		Weight		No. of Teeth
mm	in	L	ft <sup>3</sup>	kg	lb	
305	12	60	2.1	134	295	4
457	18	100	3.5	155	341	6
610	24	140	4.9	182	402	8
762	30	190	6.7	210	463	10

## STANDARD EQUIPMENT

---

- Air cleaner
- Alarm, back-up
- Audible system fault alarm
- Backhoe controls, mechanical two lever
- Battery, maintenance-free, 850 CCA
- Battery disconnect switch
- Boom transport lock
- Brace, lift cylinder
- Brake, parking, mechanical
- Brakes, hydraulically boosted, oil disc, dual pedals, interlocking
- Bucket level indicator
- Canopy, ROPS/FOPS
- Coat restraint
- Coolant/antifreeze, extended life
- Dome light (cab only)
- Diagnostic port for engine
- Differential lock, loader joystick
- Drink holders, two
- Engine, Cat C3.6 (Direct Injection Turbocharged), meets Tier 4 Final/Stage V emission standards, diesel particulate filter
- Engine enclosure, sound suppression, removable side panels
- Face seals, O-ring
- Fan, suction and guard
- Fast reversing shuttle, all gears
- Fenders, rear
- Filters, spin-on: fuel, engine oil, transmission oil, water separator
- Filters, bowl and cartridge: hydraulic fluid
- Flashing hazards/signal lights
- Floor mat
- Four wheel drive
- Four wheel drive shaft guard
- Fuel tank, fully enclosed
- Fully hinged front grill for cooling package cleaning access
- Gauge cluster: coolant temperature, fuel level, torque converter temperature, battery voltage
- Ground level fuel fill
- Halogen Lights, working (2 front, 2 rear)
- High ambient cooling package
- Hood lock, inside cab
- Hydraulic hose, XT™
- Hydraulic oil cooler
- Hydraulic oil level sight gauge
- Hydraulic valves, loader 2 function
- Hydraulic valves, backhoe 4 function
- Hydraulics, load sensing with variable displacement piston pump
- Indicator lights: wait to start, water in fuel, engine warning, warning lamp, regeneration inhibited, low engine oil pressure; LCD warnings: machine locked, service due, air filter blocked, auto idle shutdown, high coolant temperature, high torque converter temperature, high exhaust temperature, engine oil life indicator
- Instrument panel lights
- Key start/stop system
- LCD operator display with soft key controls: engine speed, hour meter, gear/direction, battery voltage, hydraulic oil temperature, torque converter temperature, coolant temperature, trip totals (fuel and hours), lifetime totals (fuel and hours), operator settings (units, brightness, programmable hoe auxiliary flow), service mode diagnostics, oil life reset, DPF force regeneration, maintenance intervals, ECM/system info
- Loader, self-leveling, return-to-dig and transmission disconnect switch
- Loader, single tilt
- Mirror, interior, rearview
- Open circuit breather
- Power receptacle, 5 volt USB, 1 internal
- Power receptacle, 12 volt, 2 internal, 1 external
- Power steering, hydrostatic
- Product Link™, cellular, network manager
- Product Link, satellite, network manager
- Seat belt, retractable, 51 mm (2 in)
- Stabilizer shoes, street
- Steering column, fixed
- Steering knob
- Seat, air suspension, vinyl cover, with armrest
- Socket, two roof
- Starting system, glow plugs
- Steering, hydrostatic
- Storage compartment, lockable
- Storage tray
- Stop and tail lights
- Swing transport lock
- Tires
- Toolbox, external, lockable
- Torque converter
- Throttle, hand and foot, electronic
- Transmission, four speed, manual, syncromesh
- Transmission neutralizer switch
- Transport tie-downs
- Vandalism locks, three
- Warning horn, electric

# 415 Backhoe Loader

## OPTIONAL EQUIPMENT

---

- Auxiliary Hydraulics, rear, Adjustable Flow
- Battery, additional, 850 CCA
- Cab, standard
- Cold weather fuel (-30° C/-22° F)
- Cold weather package, including additional battery, engine block heater, radiator antifreeze (-50° C/-58° F), cold weather fuel (-30° C/-22° F) and mounting for an ether bottle
- Counterweights, 115 kg (255 lb), 240 kg (530 lb) or 460 kg (1,015 lb)
- Fenders, front with integral steps
- Guard, boom protection plate
- Guard, stabilizer, rock
- Hydraulic valves, loader (3rd valve for MP or Quick Coupler)
- Hydraulic valves, backhoe (5th and 6th function)
- Hydraulic lines, combined function auxiliary
- Joystick controls: pilot operated, excavator style with pattern changer
- LED lights, working (2 front, 2 rear)
- Pattern changer, in cab
- Quick Coupler, hydraulic, dual lock
- Quick Coupler, manual, dual lock
- Quick Coupler, manual, pin lock
- Radio and CD player, Bluetooth®
- Ride Control
- Rotating beacon, magnetic mount
- Seat, air suspension, fabric with armrest
- Seat belt, retractable, 75 mm (3 in)
- Security system, Bluetooth
- Security System, operator display
- Side mirrors, cab, external
- Single Tilt Loader Coupler, Integrated Tool Carrier (IT) Interface
- Stabilizer pads, grouser type
- Stabilizer pads, reversible
- Steering column, tilting
- Stick, extendible
- Vandalism protection, gauge cover
- Work Tool Attachments such as buckets, forks, material handling arms, augers, hammers, brooms, cold planers and vibratory plate compactors. See your Cat dealer for more information.





# 415 Backhoe Loader

---

For more complete information on Cat products, dealer services, and industry solutions, visit us on the web at [www.cat.com](http://www.cat.com)

© 2020 Caterpillar  
All rights reserved

Materials and specifications are subject to change without notice. Featured machines in photos may include additional equipment. See your Cat dealer for available options.

CAT, CATERPILLAR, LET'S DO THE WORK, their respective logos, "Caterpillar Corporate Yellow," the "Power Edge" and Cat "Modern Hex" trade dress as well as corporate and product identity used herein, are trademarks of Caterpillar and may not be used without permission.

AEHQ8241-01 (06-2020)  
Replaces AEHQ8241  
Build Number: 07A  
(North America)





# EFFINGHAM COUNTY CHAMBER OF COMMERCE

# BUILDING BUSINESS. BUILDING COMMUNITY.

The 2023-2024 Effingham County Chamber of Commerce Community Guide & Business Directory will be the authoritative business reference for our community. It will include community information, reports on Chamber activities from the past year, and feature a Directory Section listing all chamber members.

Copies of this publication will be printed and distributed to all subscribers of the Effingham Herald and all Chamber members. It will also be available throughout the year for distribution at the Chamber Welcome Center. In addition, it will remain on the Effingham Herald and Chamber websites for the next year. Advertising opportunities in this publication are being offered exclusively to Chamber members. A portion of the advertising proceeds will go to the Chamber.

## ADVERTISING RATES

SIZE	DIMENSION	PRICE
Full Page (Bleed)*	8.625 x 11.125	850.00
1/2 Page Vertical	4.825 x 7.375	550.00
1/2 Page Horizontal	7.375 x 4.825	550.00
1/3 Page Square	4.825 x 4.825	460.00
1/6 Page Horizontal	4.825 x 2.25	275.00

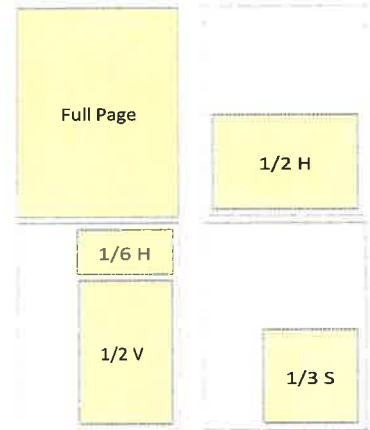

### COMBO BUY NOW TO RECEIVE 25% OFF YOUR FALL EFFINGHAM LIVING MAGAZINE AD

Strengthen your presence on the Chamber's website by running your digital ad monthly! Rotating banner ads are \$150/yr. Ad format is 600 pixels wide x 200 pixels high. These ads will rotate among advertisers every 30 seconds. Your ad is linked to your website.

### NOT A MEMBER? JOIN TODAY & RECEIVE 10% OFF OF YOUR FIRST AD IN THE DIRECTORY.

ASK FOR A MEMBERSHIP APPLICATION FOR RATES.

**Chamber Staff**  
 Chair Executive Director: Andy Briggs, CSR  
 Vice President: Chandra Williams, CPA  
 Treasurer: [Name], [Title]

**Chamber History**  
 The Effingham County Chamber of Commerce is a non-profit organization that has been serving the community since 1908. It is a member of the National Association of Chambers of Commerce.

**Past Presidents**  
 1908-1910: [Name]  
 1911-1913: [Name]  
 1914-1916: [Name]  
 1917-1919: [Name]  
 1920-1922: [Name]  
 1923-1925: [Name]  
 1926-1928: [Name]  
 1929-1931: [Name]  
 1932-1934: [Name]  
 1935-1937: [Name]  
 1938-1940: [Name]  
 1941-1943: [Name]  
 1944-1946: [Name]  
 1947-1949: [Name]  
 1950-1952: [Name]  
 1953-1955: [Name]  
 1956-1958: [Name]  
 1959-1961: [Name]  
 1962-1964: [Name]  
 1965-1967: [Name]  
 1968-1970: [Name]  
 1971-1973: [Name]  
 1974-1976: [Name]  
 1977-1979: [Name]  
 1980-1982: [Name]  
 1983-1985: [Name]  
 1986-1988: [Name]  
 1989-1991: [Name]  
 1992-1994: [Name]  
 1995-1997: [Name]  
 1998-2000: [Name]  
 2001-2003: [Name]  
 2004-2006: [Name]  
 2007-2009: [Name]  
 2010-2012: [Name]  
 2013-2015: [Name]  
 2016-2018: [Name]  
 2019-2021: [Name]  
 2022-2024: [Name]

**County Commissioners**  
 County Commissioner: [Name]  
 County Commissioner: [Name]  
 County Commissioner: [Name]  
 County Commissioner: [Name]  
 County Commissioner: [Name]

**Board of Commissioners**  
 Chairman: [Name]  
 Vice Chairman: [Name]  
 Members: [Name], [Name], [Name], [Name], [Name]

**County By The Numbers**  
 POPULATION: 142,266  
 AREA: 1,000 sq. mi.  
 COUNTY SEATED: 1802  
 COUNTY FOUNDED: 1802

**Member Directory by Category**  
 Agriculture  
 Automotive  
 Construction  
 Education  
 Entertainment  
 Food & Beverage  
 Health & Wellness  
 Home Services  
 Insurance  
 Legal  
 Manufacturing  
 Medical  
 Non-Profit  
 Professional Services  
 Retail  
 Technology  
 Transportation  
 Travel & Hospitality  
 Wholesale

**PERDUE 100**  
 100 YEARS OF SERVICE TO THE COMMUNITY

**Alphabetical Member Directory**  
 A  
 B  
 C  
 D  
 E  
 F  
 G  
 H  
 I  
 J  
 K  
 L  
 M  
 N  
 O  
 P  
 Q  
 R  
 S  
 T  
 U  
 V  
 W  
 X  
 Y  
 Z

For more information, or to place your business in the directory, please contact  
 Nichole Buchanan: nbuchanan@effinghamherald.net  
 Christy Sanders: csanders@effinghamherald.net  
 Sherrie Rippa: srippa@effinghamherald.net

## HISTORY - COMMUNITY - COMMERCE

**From:** Alicia Bywaters <[AMB@civicplus.com](mailto:AMB@civicplus.com)>  
**Sent:** Thursday, June 29, 2023 2:03 PM  
**To:** Ben Perkins <[bperkins@olivermaner.com](mailto:bperkins@olivermaner.com)>  
**Subject:** RE: Guyton, GA #15816 - Code of Ordinances - Recodification Project  
**Importance:** High

Hi Ben,

Good afternoon and thank you for your patience! In reviewing the City's account, we will need to cancel the existing recodification project and have a new contract signed.

**Code of Ordinances – Recodification(Quote Valid through September 29, 2023)**

**Base cost = \$7,800 (plus freight)**

400 single column 10-point font pages

Receipt, review and organization of materials of updated files received on 6/19/2023 (Code & Charter)

Legal analysis & research by a full-time, Municode attorney

Ø Preparation of legal memorandum by a Municode attorney

Teleconference with attorney<sup>[1]</sup>

Implementation of approved legal findings

Ø Updating State Law references

Ø Editorial preparation, proofreading and page formatting

Ø Indexing

Tables<sup>[2]</sup>, Graphics<sup>[3]</sup> & tabular matter<sup>[4]</sup>

Final proofreading and corrections

Quality control review and printing

Ø 5 printed copies, to include 3-post stamped binders and tabs

Sample adopting ordinance prepared by a Municode attorney

If the above quote for recodification is approved, we will provide an official statement of work for the City's signature.

We appreciate every opportunity to be of service to the City and I look forward to hearing from you regarding the above. If you have any questions, please do not hesitate to ask.

Thanks again and have a wonderful afternoon

Alicia

---

Please note my new email address: [amb@civicplus.com](mailto:amb@civicplus.com)

---

<sup>[1]</sup> For the initial 3-hour session, then \$150 per hour thereafter. On-site conference available upon request. Will include attorney time, travel, lodging, and per diem.

<sup>[2]</sup> The following tables will be created and are included in the base cost: supplement history table, code comparative table, State Law reference table and ordinance history table. An additional hourly charge applies for creation, modification, addition or updating of any table or schedule other than those enumerated in this footnote. This includes Traffic and Fee tables or schedules.

<sup>[3]</sup> Includes printing all copies.

<sup>[4]</sup> Tabular matter is defined as algebraic formula, or other materials that require special programs or extra editorial time to modify and prepare for inclusion in an update.

Have ordinances to send in? Please send them to [municodeords@civicplus.com](mailto:municodeords@civicplus.com)

**Alicia Bywaters**

Client Success Specialist • **22 Years at Municode**

**850.692.7013**

[amb@civicplus.com](mailto:amb@civicplus.com)



Powering and Empowering Local Governments